

Automatic Open Transition, 40–1200A



**Contactor-Based ATS
with ATC-300+ Controller**

General Description

The automatic open transition contactor-based transfer switch is the most basic design that will provide a fully functioning automatic transfer switch.

The power switching operation of Taylor's contactor-based transfer switches may be separated into the following key categories of:

- Open in-phase transition—break-before-make operation using an in-phase monitor for source synchronization
- Open delayed transition—break-before-make operation using a programmable time delay (true neutral position)

The open in-phase transition uses a two-position mechanism and the open delayed transition uses a three-position mechanism. The mechanism used to operate the Taylor electrical contactor is a momentarily energized solenoid consisting of a stationary core and a moving core that is magnetically driven by an electrical coil.

The mechanism can be electrically and mechanically operated. The design is such that the mechanism is inherently interlocked so that the device cannot be closed on the Source 1 and Source 2 at the same time under any circumstances. When switching from Source 1 to Source 2, or Source 2 to Source 1, the mechanism will only allow a break-before-make operation.

These contactor-based designs can be applied with the ATC-100 controller up to 400A. The ATC-300 controller can be applied for applications 40–1200A. Applications needing communication capability require the ATC-800 controller.

Application Description

An automatic open transition transfer switch may be used for those applications where emergency backup power is required, but a momentary loss of power is acceptable on the retransfer from emergency to normal.

Features

Standard Features— with ATC-300 Controller

- Auxiliary relay contacts:
 - Source 1 present 2NO and 2NC
 - Source 2 present 2NO and 2NC
- Switch position indication contacts:
 - Source 1 position 1NO and 1NC
 - Source 2 position 1NO and 1NC
- Source 1 and Source 2 sensing:
 - Undervoltage/underfrequency
 - Overvoltage/overfrequency
 - Three-phase rotation protection
 - Three-phase voltage unbalance
- Pretransfer signal contacts 1NO/1NC (with three-position mechanism)
- Go to emergency (Source 2)
- Seven field-programmable time delays
- LCD-based display for programming, system diagnostics and Help message display
- Mimic diagram with source available and connected LED indication
- Time-stamped history log
- System TEST pushbutton
- Programmable plant exerciser—OFF, daily, 7-, 14-, 28-day interval selectable run time 0–600 minutes no load/load with fail-safe

Optional Features

- Available surge suppression device for power/controller, engine start circuit, phone and cable connections
- Space heater with thermostat
- Ammeter—load side
- Power quality metering
- Steel cover for controller
- Open in-phase transition or time delay neutral transition
- ATC-100 controller available
- ATC-800 controller available

Commercial Design Highlights

- UL 1008 front access
- High withstand and closing ratings
- Compact design

Transfer Switches Contactor-Based Design

September 2011
Sheet 25010

Automatic Transition, 40–1200A—Technical Data

Technical Data

Table 25.1-1. UL 1008 Withstand and Close-On Ratings (kA)

UL 1008 Ampere Rating	480V	480V	600V	600V	Rating When Used with Upstream Fuse			
	Any Breaker	Specific Breaker	Any Breaker	Specific Breaker	Rating (kA)	Test Voltage	Fuse Type	Maximum Fuse Amperes
40	10	30	10	22	100	480	RK5	200
80	10	30	10	22	100	480	RK5	200
100	10	30	10	22	100	480	RK5	200
150	10	30	22	35	100	600	RK5	400
200	10	30	22	35	100	600	RK5	400
225	30	50	50	65	200	600	RK5	600
260	30	50	50	65	200	600	RK5	600
400	30	50	50	65	200	600	RK5	600
600	50	65	50	65	200	600	L, R, J, T	1600
800	50	65	50	65	200	600	L, R, J, T	1600
1000	50	65	50	65	200	600	L, R, J, T	1600
1200	50	65	50	65	200	600	L, R, J, T	1600

Table 25.1-2. UL 1008 Ratings

Mounting Type	Voltage	Current Amperes	No. of Poles	NEMA Enclosure
Fixed	600	40	2, 3, 4	Open NEMA 1 NEMA 3R NEMA 12 NEMA 4X
	600/347	80		
	480	100		
	480/277	150		
	480/240	200		
	415/240	225		
	380/220	260		
	240	400		
	240/120	600		
	220	800		
	220/127	1000		
	208/120	1200		
	120			

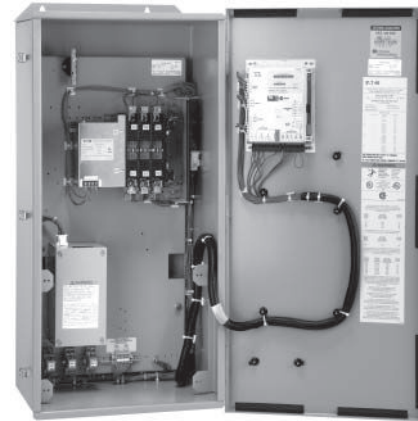

200A ATS with ATC-300+ Controller

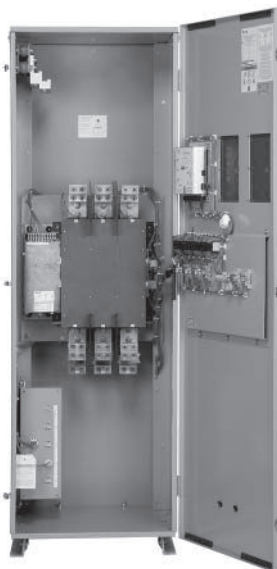

1200A ATS with ATC-300+ Controller

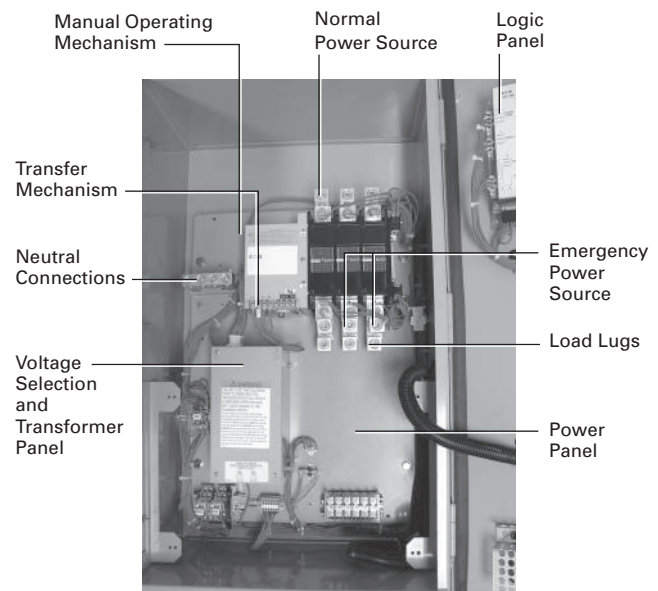

Typical Contactor-Based ATS 100–400A

Transfer Switches Contactor-Based Designs

Automatic Transition, 40–1200A—Dimensions

Dimensions—Approximate Dimensions in Inches (mm)

Table 25.1-3. Contactor-Based Transfer Switch 40–1200A Open Transition (See Figure 25.1-1 and Figure 25.1-2)

Ampere Rating	Enclosure			Bolt Pattern		Standard Terminals		
	A (Height)	B (Width)	C (Depth)	G (Horizontal)	H (Vertical)	Load Side, Normal and Standby Source	Neutral Connection	Weight in Lbs (kg)
40–100 at 480V ①	38.68 (982.5)	18.31 (465.1)	13.34 (338.8)	10.25 (260.4)	37.38 (949.5)	(1) #14–2/0	(1) #14–1/0	164 (74)
40–100 at 600V ①	38.68 (982.5)	18.31 (465.1)	13.34 (338.8)	10.25 (260.4)	37.38 (949.5)	(1) #14–2/0	(1) #14–1/0	164 (74)
150–200 at 480V ①	38.68 (982.5)	18.31 (465.1)	13.34 (338.8)	10.25 (260.4)	37.38 (949.5)	(1) #6–300 kcmil	(3) 1/0–250 kcmil	164 (74)
150–200 at 600V ①	48.74 (1237.9)	18.81 (477.8)	13.84 (351.5)	13.00 (330.2)	51.10 (1298.0)	(1) #6–300 kcmil	(3) 1/0–250 kcmil	260 (118)
225–400 at 480V ①	48.74 (1237.9)	18.81 (477.8)	13.84 (351.5)	13.00 (330.2)	51.10 (1298.0)	(2) #3/0–250 kcmil	(6) 250–500 kcmil	260 (118)
600–1200 at 480V ②	79.41 (2017.0)	25.25 (641.4) three-pole	22.46 (570.5)	18.25 (463.6)	N/A	(4) 1/0–750 kcmil	(12) 1/0–750 kcmil	600 (272)
225–1200 at 600V ②	79.41 (2017.0)	29.19 (741.4)	22.46 (570.5)	22.19 (563.6)	N/A	(4) 1/0–750 kcmil	(12) 1/0–750 kcmil	600 (272) three-pole 650 (295) four-pole

① Wallmount.

② Floor standing—height dimension includes the bottom bracket.

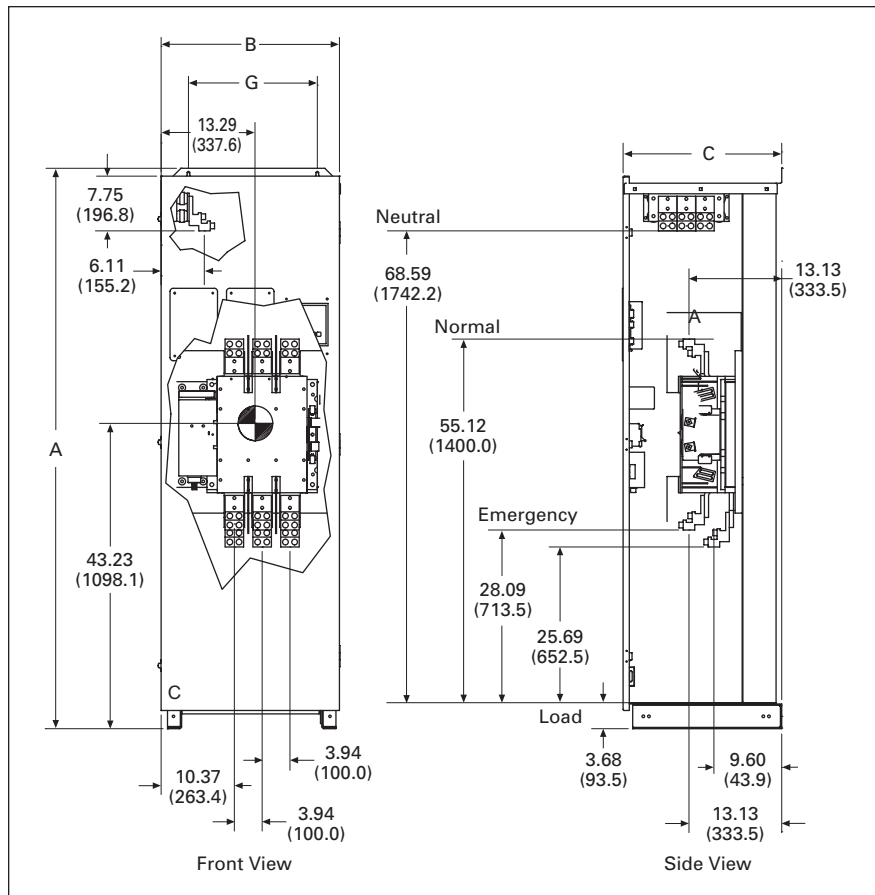

Figure 25.1-1. Automatic, Non-Automatic 600–1200A Outline NEMA 1 and NEMA 3R

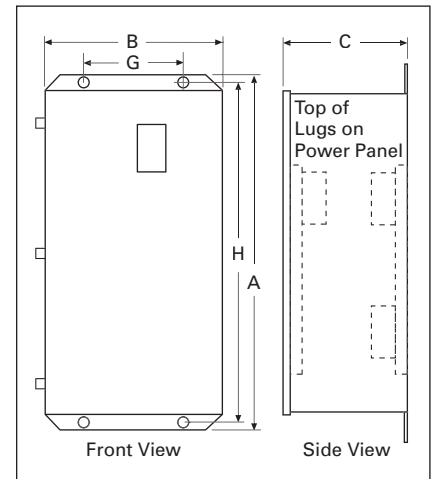

Figure 25.1-2. Automatic, Non-Automatic Up to 400A Wallmount Outline NEMA1 and NEMA 3R

ATC-300 Controller and ATC-300+ Controller



ATC-300 Controller

General Description

Transfer switches are equipped with the high-performance ATC-300+ digital transfer controller, receive rock-solid monitoring, status reporting and transfer control operation. Its superior design and robust construction make the ATC-300+ the industry benchmark for critical and distributed power systems.

The ATC-300+ will supersede the ATC-300 controller for units supplied after September 2011. The ATC-300+ will have the same form and fit as the ATC-300. Size and mounting dimensions are identical. In addition, the ATC-300+ will have additional optional capability for manual retransfer, Source 2 emergency inhibit and RS-485 Modbus communication capability.

Application Description

Taylor's ATC-300+ controller-based automatic transfer switch is designed to provide unmatched performance, reliability and versatility for critical standby power applications.

Features, Benefits and Functions

Standard Features

- Auxiliary relay contacts:
 - Source 1 present 2NO and 2NC
 - Source 2 present 2NO and 2NC
- Switch position indication contacts:
 - Source 1 position 1NO and 1NC
 - Source 2 position 1NO and 1NC
- Source 1 and Source 2 sensing:
 - Undervoltage/underfrequency
 - Overvoltage/overfrequency
 - Three-phase rotation protection
 - Three-phase voltage unbalance
- Pretransfer signal contacts 1NO/1NC
- Go to emergency (Source 2)
- Source-2 emergency inhibit contact
- Seven field-programmable time delays
- LCD-based display for programming, system diagnostic and Help message display
- Mimic diagram with source available and connected LED indication
- Time-stamped history log
- System TEST pushbutton
- Programmable plant exerciser—OFF, daily, 7-, 14-, 28-day interval selectable run time 0–600 minutes no load/load with fail-safe

Optional Features

- Suitable for use as service equipment in the standard enclosure size when used with breaker-based design transfer switches
- Available UL 1449 3rd Edition compliant surge protection devices
- Integrated distribution panels
- Field-selectable multi-tap transformer panel permits operation on a wide range of system voltages
- Integral overcurrent protection available when used with breaker-based design transfer switches
- Space heater with thermostat
- Ammeter—load side
- Power quality metering
- Manual retransfer selector switch
- Stainless steel cover for controller
- Source 2 inhibit
- Manual retransfer
- RS-485 communication capability

Standards and Certifications

- UL listed component
- Meets UL 1008
- Meets intent of UL 991
- Meets IEC 1000-4-2, 1000-4-3, 1000-4-4, 1000-4-5, 1000-4-6, 1000-4-11
- Meets CISPR 11, Class A
- Complies with FCC Part 15, Class A

Technical Data

Table 25.4-5. ATC-300+ Controller Specifications

Description	Specification
Input control voltage	65–145 Vac 50/60 Hz
Voltage measurements of	Source 1 V_{AB} Source 1 V_{BC} Source 1 V_{CA} Source 2 V_{AB} Source 2 V_{BC} Source 2 V_{CA}
Voltage measurement range	0–790 Vac rms (50/60 Hz)
Voltage measurement accuracy	±2% of nominal input voltage
Frequency measurement for	Source 1 and Source 2
Frequency measurement range	40–70 Hz
Frequency measurement accuracy	±0.3 Hz
Undervoltage dropout range Breaker/switch style ATS Contactor style ATS	50–97% of the nominal system voltage 78–97% of the nominal system voltage
Undervoltage pickup range	(Dropout +2%) to 99% of the nominal system voltage
Overvoltage dropout range Breaker/switch style ATS Contactor style ATS	105–120% of the nominal system voltage 105–110% of the nominal system voltage
Overvoltage pickup range	103% to (dropout –2%) of the nominal system voltage
Underfrequency dropout range	90–97% of the nominal system frequency
Underfrequency pickup range	(Dropout +1 Hz) to 99% of the nominal system frequency
Overfrequency dropout range Breaker/switch style ATS Contactor style ATS	103 to 110% of the nominal system frequency 103 to 105% of the nominal system frequency
Overfrequency pickup range	101% to (dropout –1 Hz) of the nominal system frequency
Operating temperature range	–20° to +70°C (–4° to +158°F)
Storage temperature range	–0° to +85°C (–22° to +185°F)
Operating humidity	0–95% relative humidity (noncondensing)
Operating environment	Resistant to ammonia, methane, nitrogen, hydrogen and hydrocarbons
Generator start relay	5A, 1/6 hp at 250 Vac/5A at 30 Vdc with a 150W maximum load
K1, K2, pretransfer, alarm relays, K3, K4	10A, 1–3 hp at 250 Vac/10A at 30 Vdc
Enclosure compatibility	NEMA 1, NEMA 3R and NEMA 12 UV-resistant ATC-300 faceplate

The following set points are programmable if the corresponding feature is programmed.

Table 25.4-6. ATC-300+ Programming Features/Set Points ①

Set Point	Set Point Units	Description	Range	Factory Default
TDES	Minutes: seconds	Time delay engine start	0–120 seconds	0:03
TDNE	Minutes: seconds	Time delay normal to emergency	0–1800 seconds	0:00
TDEN	Minutes: seconds	Time delay emergency to normal	0–1800 seconds	5:00
TDEC	Minutes: seconds	Time delay engine cool-off	0–1800 seconds	5:00
TDN	Minutes: seconds	Time delay neutral	0–120 seconds	0:00
PLANT EXER	Days	Plant exerciser programming	Off, daily, 7-day, 14-day or 28 day	Off
TEST MODE	—	Test Mode	0, 1 or 2 (0 = no load engine test, 1 = load engine test, 2 = disabled)	0
TER	Hours: minutes	Engine run test time	0–600 min	5:00
TPRE	Minutes: seconds	Pre-transfer delay timer	0–120 sec	0:00
PHASES	—	Three-phase or single-phase	1 or 3	As ordered
VOLT UNBAL	Volts	Voltage unbalanced	0 or 1 (1 = enabled)	1
UNBAL DROP %	Percent	Percent for unbalanced voltage dropout	5–20% of phase voltage unbalance	20%
UNBAL PICK %	Percent	Percent for unbalanced voltage pickup	Dropout minus (UNBAL DROP % –2) to 3%	10%
UNBAL DELAY	Seconds	Unbalanced delay timer	10–30	0:20
TDEF	Seconds	Time delay emergency fail timer	0–6 sec	6
PHASE REV	—	Phase reversal	OFF, ABC or CBA	OFF

① Complete list of programming selections found in IB01602009E.

Transfer Switches Standard and Optional Features

Contactor-Based—Automatic Transfer Switch Features

Standard and Optional Features

Table 25.5-1. Contactor-Based—Automatic Transfer Switch Features

Feature Number	Description	Open Transition						Closed Transition
		RLC1	ATC1	ATC3	ATC8	BIC3	BIC8	CBC8
		Residential Contactor Switch ATC-100 Controller	Contactor Switch ATC-100 Controller 40–400A Only	Contactor Switch ATC-300 Controller 40–1200A	Contactor Switch ATC-800 Controller Open Transition	Bypass Isolation Contactor Switch Open Transition ATC-300 Controller	Bypass Isolation Contactor Switch Open Transition ATC-800 Controller	Bypass Isolation Contactor Switch Closed Transition ATC-800 Controller
1	Timers							
1a	Time delay normal to emergency (TDNE) Fixed 2 seconds or 15 seconds	S	S	—	—	—	—	—
	Adjustable 0–1800 seconds	—	—	S	S	S	S	S
2	Time delay engine start (TDES) Fixed 3 seconds	S	S	—	—	—	—	—
	Adjustable 0–120 seconds	—	—	S	S	S	S	S
3	Time delay emergency to normal (TDEN) Fixed 1 minute	S	S	—	—	—	—	—
	Adjustable 0–1800 seconds	—	—	S	S	S	S	S
4	Time delay engine cooldown (TDEC) Fixed 5 minutes	S	S	—	—	—	—	—
	Adjustable 0–1800 seconds	—	—	S	S	S	S	S
5	Emergency (S2) source sensing							
5H	Phase reversal	—	—	S	O	S	O	O
5J	All-phase undervoltage/underfrequency	S	S	S	S	S	S	S
5K	All-phase overvoltage/overfrequency	—	—	S	S	S	S	S
5L	All-phase voltage unbalance and phase loss	—	—	S	O	S	—	—
5N	All-phase overfrequency	S	S	—	—	—	—	—
6	System or engine test							
6B	System test pushbutton	S	S	S	S	S	S	S
6D	Maintained 2-position test switch	—	—	—	—	—	—	—
6H	Maintained 4-position test switch	—	—	—	O	—	O	O
7	Time delay emergency fail (TDEF) Fixed 6 seconds	S	S	—	—	—	—	—
7a	Time delay emergency fail (TDEF) Adjustable 0–6 seconds)	—	—	S	S	S	S	S
8	Pushbutton bypass							
8C	Bypass TDEN	—	—	S	S	S	S	S
8D	Bypass TDNE	—	—	S	S	S	S	S
9	Maintenance selector switch							
9B	Electrical operator isolator switch	—	—	O	O	O	O	O
10	Preferred source selector							
10B	Utility to utility or utility to generator	—	—	—	S	—	S	S
10D	Generator to generator	—	—	—	S	—	S	S
12C	Indicating lights Normal (S1) source connected	S	S	S	S	S	S	S
12D	Emergency (S2) source connected	S	S	S	S	S	S	S
12G	Normal (S1) source available	S	S	S	S	S	S	S
12H	Emergency (S2) source available	S	S	S	S	S	S	S
14	Auxiliary relay contacts							
14C	Normal (S1) source available 4 Form C	—	—	O	—	O	O	O

Note: S = Standard, O = Optional

Transfer Switches Standard and Optional Features

September 2011
Sheet 25068

Contactor-Based—Automatic Transfer Switch Features

Table 25.5-1. Contactor-Based—Automatic Transfer Switch Features (Continued)

Feature Number	Description	Open Transition						Closed Transition
		RLC1	ATC1	ATC3	ATC8	BIC3	BIC8	CBC8
		Residential Contactor Switch ATC-100 Controller	Contactor Switch ATC-100 Controller 40–400A Only	Contactor Switch ATC-300 Controller 40–1200A	Contactor Switch ATC-800 Controller Open Transition	Bypass Isolation Contactor Switch Open Transition ATC-300 Controller	Bypass Isolation Contactor Switch Open Transition ATC-800 Controller	Bypass Isolation Contactor Switch Closed Transition ATC-800 Controller
14D	Emergency (S2) source available 4 Form C	—	—	O	—	O	O	O
14E	Normal (S1) source available 1 Form C	—	—	S	—	—	—	—
14F	Emergency (S2) source available 1 Form C	—	—	S	—	—	—	—
14G	Normal (S1) source available 2 Form C	—	S	—	S	S	S	S
14H	Emergency (S2) source available 2 Form C	—	S	—	S	S	S	S
15	Position contacts							
15E	Normal (S1) source position 1 Form C	—	S	S	S	S	S	S
15F	Emergency (S2) source position 1 Form C	—	S	S	S	S	S	S
15G	Position indicating contact normal (3 Form C)	—	O	O	O	O	O	O
15H	Position indicating contact emergency (3 Form C)	—	O	O	O	O	O	O
15M	Source 2 load shed contacts 4 Form C (must order as a separate field-installed kit)	O	—	—	—	—	—	—
16S	Service equipment /overcurrent protection (S1)	O	—	—	—	—	—	—
18	Metering	—	O	O	O	O	O	O
	IQ 130	—	O	O	O	O	O	O
	IQ 140	—	O	O	O	O	O	O
	IQ 150	—	O	O	O	O	O	O
	IQ 250	—	O	O	O	O	O	O
	IQ 260	—	O	O	O	O	O	O
	PXM 2250	—	O	O	O	O	O	O
	PXM 2260	—	O	O	O	O	O	O
	PXM 2270	—	O	O	O	O	O	O
18W	Analog ammeter one per phase	—	O	O	O	O	O	O
21A	Non-standard terminals	—	—	—	—	—	—	—
23	Plant exciser							
23A	Selectable—disabled/7-, 14-, 28-day interval, FIXED 15 minutes, load/no load, with fail-safe	S	S	—	—	—	—	—
23J	Selectable—disabled/7 day interval, 0–600 minutes, load/no load, with fail-safe	—	—	—	S	—	S	S
23K	Selectable—disabled/7-, 14-, 28-day interval, 0–600 minutes, load/no load, with fail-safe	—	—	S	—	S	—	—
23L	24-hour, 7-day, 365-day programmable programmable plant exciser	—	—	O	O	O	O	O
26	Normal (S1) source sensing							
26D	Go to emergency (S2) input	—	—	S	S	S	S	S
26H	Phase reversal protection	—	—	S	O	S	O	O
26J	All-phase undervoltage/underfrequency	—	—	S	S	S	S	S
26K	All-phase overvoltage/overfrequency	—	—	S	S	S	S	S
26L	Three-phase voltage unbalance/phase loss	—	—	S	O	S	O	O
26M	Allows operation with generator with utility sensing (option available only through a field-installed kit)	O	O	—	—	—	—	—
26P	All-phase undervoltage	S	S	—	—	—	—	—

Note: S = Standard, O = Optional

Transfer Switches Standard and Optional Features

Contactor-Based—Automatic Transfer Switch Features

Table 25.5-1. Contactor-Based—Automatic Transfer Switch Features (Continued)

Feature Number	Description	Open Transition						Closed Transition
		RLC1	ATC1	ATC3	ATC8	BIC3	BIC8	CBC8
		Residential Contactor Switch ATC-100 Controller	Contactor Switch ATC-100 Controller 40–400A Only	Contactor Switch ATC-300 Controller 40–1200A	Contactor Switch ATC-800 Controller Open Transition	Bypass Isolation Contactor Switch Open Transition ATC-300 Controller	Bypass Isolation Contactor Switch Open Transition ATC-800 Controller	Bypass Isolation Contactor Switch Closed Transition ATC-800 Controller
29	Alternative transfer modes of operation	—	—	—	—	O	S	S
29D	Dual ATS bypass isolation	—	—	—	—	O	S	S
29G	Selector switch for automatic or non-automatic operation (switch must be labeled as non-automatic)	—	—	O	O	O	O	O
29J	Automatic transfer operation with selectable (via programming) automatic or non-automatic retransfer operation with fail-safe	—	—	O	O	—	O	O
32	Delayed transfer operation modes	—	—	S	S	S	S	—
32A	Time delay neutral adjustable 0–120 seconds (available on 3-position contactors)	—	—	S	S	S	S	—
32B	Load voltage decay adjustable (available on 3-position contactors)	—	—	—	O	—	O	—
32C	2–30% nominal voltage In-phase monitor defaults to load voltage decay	—	—	—	—	—	—	—
32D	In-phase monitor defaults to time delay neutral	—	—	—	—	—	—	—
32E	Delay transition timer adjustable 3–60 seconds	—	—	—	—	—	—	—
32F	In-phase monitor (2-position contactors only)	—	S	S	S	—	—	—
32G	Time delay neutral fixed 0 or 2 seconds (available on 3-position contactors and breaker-based design)	—	—	—	—	—	—	—
34	Logic extender cable	—	—	—	—	—	—	—
34A	48.00 inches (1219.0 mm)	—	—	—	—	—	—	—
34C	96.00 inches (2438.0 mm)	—	—	—	—	—	—	—
34E	144.00 inches (365.08 mm)	—	—	—	—	—	—	—
35A	Pretransfer Sig-I contacts 1 Form C	—	—	S	O	S	O	—
36	Load shed from emergency	—	—	—	S	—	S	S
37	Go to isolated position (not SE rated) ①	—	—	—	O	—	—	—
38	Stainless steel device covers	—	—	—	O	—	—	—
38A	SS cover for device plate or service equipment	—	—	—	O	—	—	—
38B	Disconnect SS cover for controller	—	O	O	O	O	O	O
41	Space heater with thermostat	—	—	—	—	—	—	—
41A	100 watts	—	O	O	O	O	O	O
41E	375 watts	—	—	—	—	—	O	O
42	Seismic IBC, UBC	S	S	S	S	S	S	S
45	Load sequencing contacts	—	—	—	—	—	—	—
45A	Load sequencing contacts (1)	—	—	—	O	—	O	O
45B	Load sequencing contacts (2)	—	—	—	O	—	O	O
45C	Load sequencing contacts (3)	—	—	—	O	—	O	O
45D	Load sequencing contacts (4)	—	—	—	O	—	O	O
45E	Load sequencing contacts (5)	—	—	—	O	—	O	O
45F	Load sequencing contacts (6)	—	—	—	O	—	O	O
45G	Load sequencing contacts (7)	—	—	—	O	—	O	O
45H	Load sequencing contacts (8)	—	—	—	O	—	O	O

① Select 16S for service entrance rating on RLC1.

Note: S = Standard, O = Optional

Transfer Switches Standard and Optional Features

September 2011
Sheet 25070

Contactor-Based—Automatic Transfer Switch Features

Table 25.5-1. Contactor-Based—Automatic Transfer Switch Features (Continued)

Feature Number	Description	Open Transition						Closed Transition
		RLC1	ATC1	ATC3	ATC8	BIC3	BIC8	CBC8
		Residential Contactor Switch ATC-100 Controller	Contactor Switch ATC-100 Controller 40–400A Only	Contactor Switch ATC-300 Controller 40–1200A	Contactor Switch ATC-800 Controller Open Transition	Bypass Isolation Contactor Switch Open Transition ATC-300 Controller	Bypass Isolation Contactor Switch Open Transition ATC-800 Controller	Bypass Isolation Contactor Switch Closed Transition ATC-800 Controller
45I	Load sequencing contacts (9)	—	—	—	O	—	O	O
45J	Load sequencing contacts (10)	—	—	—	O	—	O	O
47	Closed transition operation-I modes (user must specify mode)							
47C	Closed transition in-phase with default to load voltage decay	—	—	—	—	—	—	O
47D	Closed transition	—	—	—	—	—	—	S
47E	Closed transition in-phase with defaults to time delay neutral	—	—	—	—	—	—	O
48	Communications							
48A	IPONI module (INCOM communications)	—	—	—	O	—	O	O
48D	Ethernet communication 10Base-T only (PXG400 Gateway)	—	—	—	O	—	—	O
48F	EPONI module (10Base-T and 10Base-FL) MPONI module (MODBUS)	—	—	O	O	—	O	O
48R	Remote annunciator	—	—	—	O	—	O	O
48RAC	Remote annunciator with control	—	—	O	O	O	O	O
49B	Sensing isolation transformer	—	—	O	O	—	—	—
49C	Multi-tap voltage transformer (at 240, 208 and 120 Vac not included)	—	S	S	S	S	S	S
51	Surge protection device	—	O	O	O	O	O	O
51D1	50 kA CVX surge device source 1	—	O	O	O	O	O	O
51F1	100 kA CVX surge device source 1	—	O	O	O	O	O	O
80A	Emergency (S2) inhibit contact	—	—	O	S	—	S	S

Note: S = Standard, O = Optional

Feature Description

Timers

1. Time Delay Normal to Emergency (TDNE)

Provides a time delay to allow for the generator to warm up before transferring the load to the emergency source. Timing begins only after the Emergency Source becomes available and is deemed good based on the programmable voltage and frequency set points in the controller.

2. Time Delay Engine Start (TDES)

Provides a time delay before initiating the generator start cycle. This is to account for momentary power outages or voltage fluctuations of the normal source. Provides a Form C contact to the generator starter circuit.

3. Time Delay Emergency to Normal (TDEN)

Provides a time delay of the retransfer operation to permit stabilization of the normal source. Timing begins only after the normal source becomes available and is deemed good based on the programmable voltage and frequency set points in the controller. This function is fail-safe protected.

4. Time Delay Engine Cooldown (TDEC)

Provides a time delay before initiating the generator stop cycle after the retransfer operation. This allows the generator to cool down by running unloaded. Timing begins on completion of the retransfer cycle.

Source 2 Sensing

5. Source 2—Monitoring and Protection

Provides monitoring and protection based on the Source 2 voltage and/or frequency set points. All **Feature 5** monitoring and protection functions are fail-safe operations.

5J. All-Phase Undervoltage/Underfrequency Protection

Provides undervoltage/underfrequency monitoring and protection based on programmable set points in the controller.

5K. All-Phase Overvoltage/Overfrequency Protection

Provides overvoltage/overfrequency monitoring and protection based on programmable set points in the controller.

5H. Three-Phase Rotation Protection

Provides three-phase reversal sensing in order to protect against transferring to an out-of-phase source. The controller will treat the opposite source as unavailable if the sources are out of phase, based on programmable set points in the controller.

5L. Three-Phase Voltage Unbalance/Phase Loss

Provides phase loss detection from blown fuses on the Source 2 supply circuit.

6B. Test Operators

Automatic transfer switches are provided with a controller faceplate test pushbutton that simulates a loss of the Source 1 as standard. All programmed time delays (TDNE, TDEN, etc.) will be performed as part of the test. Engine run time of the test is equal to the plant exerciser programmed set point. All tests are fail-safe protected.

6H. 4-Position Test Selector Switch (FPSS)

Provides a door-mounted 4-position, maintained contact selector switch marked "Auto," "Test," "Engine Start," and "Off." The FPSS is fail-safe protected, except for the "Off Position." Transfer switch operation is determined by the switch position. Transfer switch operations are as follows:

"Auto"—Automatic operation mode.

"Test"—A load test is performed until the switch is moved to another position.

"Engine Start"—A no-load test is performed until the switch is moved to another position.

"Off"—The automatic transfer controller and engine start contact are disabled. A white pilot light is provided to indicate that the FPSS is in the "Off" position.

7. Time Delay Emergency Fail (TDEF)

Provides a time delay that prevents a connected emergency source from being declared "unavailable" based on the customer's set points. This is to account for momentary generator fluctuations. If the Source 2 remains in a failed state, then 0.5 second after the TDEF timer expires the transfer switch will proceed with the programmed sequence for retransfer if Source 1 is available. This time delay is only implemented when Source 2 is a generator.

Note: This feature is also enabled when large loads cause generator output to drop below customer set points.

8. Time Delay Bypass Pushbutton

Provides a momentary contact pushbutton to bypass the TDNE (**Feature 1**) and/or TDEN (**Feature 3**) time delays. The Time Delay Bypass Pushbutton contact, when closed, will reduce any or all of the programmed time delay to zero. Must be executed when TDNE or TDEN timer is displayed on the controller.

8C. Bypass Time Delay Emergency to Normal (TDEN)

8D. Bypass Time Delay Normal to Emergency (TDNE)

9B. Maintenance Selector Switch (MSS)

Provides a 2-position, maintained contact selector switch marked "Operate" and "Disable." When the MSS is placed in the "Disable" position, the controller logic will be disconnected from the transfer motor circuit. The MSS is placed in the "Operate" position for normal automatic operation.

10. Preferred Source Selector

Provides a means to designate either Source 1 or Source 2 as the "Preferred" source. The "Preferred" source is the source that the transfer switch will connect the load to if it is available.

Note: This is a programmable software feature not an actual switch.

10B. Preferred Source Selector

Provides a programmable source selector for use on systems comprised of dual utility or utility and engine/generator power sources.

10D. Preferred Source Selector

Provides a programmable source selector for use on systems comprised of dual engine/generator power sources. (Dual engine starting circuits are provided.)

12C. Source 1—Load Connected

Provides a green indication that indicates the load is connected to Source 1 when lit.

12D. Source 2—Load Connected

Provides a red indication that indicates the load is connected to Source 2 when lit.

Automatic Transfer Switch Features

Feature Description (Continued)

12G. Source 1—Present

Provides a white or amber indication “Depending on the Controller” that Source 1 has power; however, this does not indicate whether Source 1 is acceptable.

12H. Source 2—Present

Provides an amber indication that Source 2 has power; however, this does not indicate whether Source 2 is acceptable.

Overcurrent Trip Indication

Available only with integral overcurrent protection (**Feature 16**) (shown on automatic transfer controller display).

12L. Source 1 Trip Indication

The automatic transfer controller display will read “Lockout” if the Source 1 circuit breaker is in the “tripped” position.

12M. Source 2 Trip Indication

The automatic transfer controller display will read “Lockout” if the Source 2 circuit breaker is in the “tripped” position.

14. Relay Auxiliary Contacts

14C. Source 1 Present

Provides 4 Form C relay auxiliary contacts. The relay is energized when Source 1 is present.

14D. Source 2 Present

Provides 4 Form C relay auxiliary contacts. The relay is energized when Source 2 is present.

14E. Source 1 Available

Provides 1 Form C relay auxiliary contact. The relay is energized when Source 1 is available and within the controller’s programmable set points.

14F. Source 2 Available

Provides 1 Form C relay auxiliary contact. The relay is energized when Source 2 is available and within the controller’s programmable set points.

14G. Source 1 Present

Provides 2 Form C relay auxiliary contacts. The relay is energized when Source 1 is present.

14H. Source 2 Present

Provides 2 Form C relay auxiliary contacts. The relay is energized when Source 2 is present.

15. Switch Position Indication Contact

Provides a contact that indicates if the power switching device is in the “open” or “closed” position.

15E. Source 1 Position Indication Contact

Provides 1 Form C contact that indicates the position of the Source 1 power switching device.

15F. Source 2 Position Indication Contact

Provides 1 Form C contact that indicates the position of the Source 2 power switching device.

15M. Source 2 Load Shed Contacts

Provides 4 Form C contacts to initiate a load circuit disconnect while on Source 2. This gives the user the capability of selectively choosing not to run certain loads while on Source 2.

16B. Integral Overcurrent Protection on Both Power Source Switching Devices

Provides integral overcurrent protection on both Source 1 and Source 2 power switching devices.

16E. Integral Overcurrent Protection on the Source 2 Power Switching Device

Provides integral overcurrent protection on the Source 2 power switching device.

16N. Integral Overcurrent Protection on the Source 1 Power Switching Device

Provides integral overcurrent protection on the Source 1 power switching device.

16S. External Overcurrent Protection on the Source 1 Power Switching Device

Provides overcurrent protection on the Source 1 power switching device.

18. Metering

The ATS controller provides voltage and frequency readings. If additional metering functions are required, Taylor offers a series of digital meters that may be added to the ATS. The meter type can provide simple current and voltage readings or more capable meters providing Power, Demand and energy readings.

Available with an optional communications interface. (See **Feature 48**—Communications for available communication modules.)

Feature 18 metering options include all required external devices (CTs, etc.) for a fully functioning metering system.

IQ 130/140/150

IQ 130

This digital meter provides basic current and voltage per phase (L-L, L-N) and min./max. readings (I, V). Optional communication RS-485, Modbus RTU.

IQ 140

In addition to basic current and voltage, will provide frequency, power measurements real, reactive and apparent power, total (W, VAR, VA). Optional communication RS-485, Modbus RTU.

IQ 150

In addition to basic current/voltage/frequency and power readings, will provide Energy Real reactive and apparent (Wh, VAR, Vah). Optional communication RS-485, Modbus RTU.

IQ 250/260

IQ 250

This digital meter provides current per phase and current demand, voltage (L-L, L-N) and frequency. Power, energy and demand readings. Real, reactive and apparent power and energy, power factor. RS-485 communications, Modbus RTU or ASCII. Optional I/O slots available.

IQ 260

In addition to all of the features of the IQ 250, power quality analysis is available with THD voltage and current per phase.

Power Xpert 2000

Provides either a Power Xpert PXM 2250, PXM 2260 or PXM 2270 meter.

Power Xpert 4000, 6000, 8000

Provides one of the Power Xpert Meters with or without graphic displays.

18W. Ammeter Side Metering

Provides an ammeter for monitoring the load side circuit.

20A. Rear Bus Provisions

Provides Source 1, Source 2 and Load Circuit rear accessible bus stabs with provision for bus bar connection. Taylor transfer switches are provided with either front or rear (dependant on switch type) connected solderless screw-type terminals for power cable connection as standard.

Transfer Switches Standard and Optional Features

Automatic Transfer Switch Features

Feature Description (Continued)

21A. Optional Power Cable Connection Terminals

Taylor transfer switches are provided as standard with Source 1, Source 2 and load circuit solderless screw-type terminals for power cable connection. Alternate terminal wire sizes, and compression lug provisions may be available dependant on transfer switch type and ampere rating.

Plant Exerciser

23A. Plant Exerciser With Fail-Safe

Provides a means for automatic testing of the engine generator set or standby power system. All programmed time delays in the controller will be performed during plant exerciser operations.

Programmable set points for test intervals are start time, either disabled, daily, 7, 14 or 28 days.

15-minute fixed engine test time.

Test may be performed with or without load transfer. Test may be manually cancelled during the operation. This function is fail-safe protected.

23J. Plant Exerciser (PE) With Fail-Safe

Provides a means for automatic testing of the engine generator set or standby power system. All programmed time delays in the controller will be performed during the plant exerciser operation.

Programmable set points for test interval are start time, either disabled or 7 days, and engine test time.

Test may be performed with or without a load transfer. Test may be manually cancelled during the operation. This is a fail-safe operation.

23K. Plant Exerciser With Fail-Safe

Provides a means for automatic testing of the engine generator set or standby power system. All programmed time delays in the controller will be performed during plant exerciser operations.

Programmable set points for test intervals are start time, either disabled, daily, 7, 14 or 28 days, engine test time.

Test may be performed with or without load transfer. Test may be manually cancelled during the operation. This function is fail-safe protected.

26D. Go to Emergency (Source 2)

Provides the capability for an external contact closure to initiate a transfer to the Source 2 power source. This includes starting the generator, performing the programmed time delays and the transfer operation. Retransfer will occur when the external contact is opened. This is a fail-safe function.

Source 1 Sensing

26. Source 1—Monitoring and Protection

Provides Source 1 monitoring and protection functions. If Source 1 fails, then the automatic transfer controller will begin the sequence of operations necessary to transfer the load to Source 2. All **Feature 26** monitoring and protection functions are fail-safe operations.

26H. Three-Phase Rotation Protection

Provides three-phase reversal sensing in order to protect against transferring to an out-of-phase source. The controller will treat the opposite source as unavailable if the sources are out of phase, based on programmable set points in the controller.

26J. All-Phase Undervoltage/Underfrequency Protection

Provides all-phase undervoltage/underfrequency monitoring and protection based on programmable set points in the controller.

26K. All-Phase Overvoltage/Overfrequency Protection

Provides all-phase overvoltage/overfrequency monitoring and protection based on programmable set points in the controller.

26L. Three-Phase Voltage Unbalance/Phase Loss

Provides phase loss detection from blown fuses on the Source 1.

26M. Generator Utility Sensing

Allows for the switch to operate with generators that have internal utility sensing. This option comes as a kit that needs to be field installed.

26N. All-Phase Undervoltage Protection

Provides undervoltage protection for Source 1 (ATC-100 Controller only).

29. Transfer Operation Modes

Provides standard or optional transfer modes, mode selection devices and operational methods for transfer switches.

29J. Automatic Transfer or Automatic Transfer With Non-Automatic Retransfer Operation

Provides a field-selectable programmable set point that permits the transfer switch to operate in one of the following two transfer modes (A or B):

- A. Fully automatic operation.
- B. Automatic engine/generator startup and automatic transfer operation from Source 1 to Source 2. Manual pushbutton operation is required to initiate the retransfer operation and engine/generator shutdown. The pushbutton for manual retransfer operation is included. This is fail-safe protected.

29G. Automatic/Manual Operation With Selector Switch

Provides 2-position selector switch (labeled Auto/manual) that permits selection of the automatic or manual transfer. When in the "Auto" position, the transfer switch operates with fully automatic transfer, retransfer and generator startup and shutdown operations. When in the "Manual" position, manual operation is required to initiate the generator startup or retransfer with generator shutdown operations.

Note: Transfer switches with **Feature 29** must be labeled as non-automatic transfer switch equipment.

32. Delayed Transition Transfer Modes for Open Transition Transfer Switches

Provides delayed transition transfer modes for an open transition transfer switch. Often used in systems with inductive loads, a delayed transition transfer switch may prevent or reduce inrush currents due to out-of-phase switching of inductive loads.

32A. Time Delay Neutral

Provides a time delay in the neutral position during the transfer and retransfer operations during which both Source 1 and Source 2 are disconnected from the load circuit. This allows inductive loads time to reach a safe voltage and eliminate back EMF. The time delay is programmable and is the same for both transfer and retransfer operations. This is a passive feature that requires the consulting engineer/installer to determine the settings based on how the user will operate the facility. Adjustable 0–120 seconds.

Feature Description (Continued)

32B. Load Voltage Decay

Provides load voltage measurement to sense back EMF that is generated when the transfer switch is the neutral position. It provides a delay in transfer in either direction if an unacceptable level is sensed as established by a programmed set point. This is an active feature that adapts to how the facility is operating in order to minimize neutral position wait time, but ensure safety. Adjustable 2–30% of nominal voltage.

32C. In-Phase Transition With Default to Load Voltage Decay

Provides in-phase transition, which is a feature that will permit a transfer or retransfer between two available sources that have a phase angle difference near zero. The in-phase transition feature includes permissible frequency difference and synchronization time set points. In the event Source 1 and Source 2 fail to synchronize within the permitted frequency difference and time, then the controller defaults to the load voltage decay operation as described in **Feature 32B**. Adjustable frequency difference 0.0–3.0 Hz. Adjustable synchronization time allowance 1–60 minutes.

32D. In-Phase Transition With Default to Time Delay Neutral

Provides in-phase transition, which is a feature that will permit a transfer or retransfer only between two available sources that have a phase angle difference near zero. The in-phase transition feature includes permissible frequency difference and synchronization time set points. In the event Source 1 and Source 2 fail to synchronize within the permitted frequency difference and time, then the controller defaults to the time delay neutral operation as described in **Feature 32A**. Adjustable frequency difference 0.0–3.0 Hz. Adjustable synchronization time allowance 1–60 minutes.

32E. Delayed Transition

The transfer and re-transfer operations during which both Source 1 and Source 2 are disconnected from the load circuit. The time delay is programmable and the same for both transfer and re-transfer operation. Adjustable 3–60 seconds.

32F. In-Phase Transition

Provides in-phase transition, this feature will permit a transfer or retransfer between two available sources that have a phase angle difference of 8 degrees or less. The in-phase transition feature includes permissible frequency difference and synchronization time set points. In the event Source 1 and Source 2 fail to synchronize within the permitted frequency difference and time, the Alarm relay will energize and “Failed to Sync” will be displayed on Line 1 of the controller. After resetting the alarm, another in-phase transition may be attempted or a non-synchronized transfer may be initiated by failing the connected source. The adjustable frequency difference is 0.0 to 3.0 Hz. If the synchronization does not occur within a specified amount of time, the Alarm relay will energize and the failure will be logged into the transfer history as either “Sync Fail - Freq” or “Sync Fail - Phase” depending on whether the frequency difference or the phase difference was excessive.

32G. Time Delay Neutral

This feature provides a time delay in the neutral position during the transfer and retransfer operations during which both the utility source and the generator source are disconnected from the load circuit. TDN cannot be implemented on a transfer switch using a 2-position contactor.

Jumper selectable at disable (0 seconds) or enable (2 seconds).

Logic Extender Cable

34A. 48 Inches (1219 mm)

Provides logic extension cable with connectors.

34C. 96 Inches (2438 mm)

Provides logic extension cable with connectors.

34E. 144 Inches (3658 mm)

Provides logic extension cable with connectors.

34F. 100 Inches (2540 mm)

Provides logic extension only for open Magnum ATS.

35A. Pretransfer Signal With 1 Form C Contact

Provides a signal prior to the transferring of the load. Will not transfer until the programmable delay set point in the controller is reached. If both sources are not available, this option will ignore the time delay set in the controller.

36. Load Shed From Emergency

Provides the capability for an external NC contact to initiate a load circuit disconnection from the Source 2 power source. If the load circuit is connected to Source 2 and the contact is opened, then a retransfer to Source 1 is completed if Source 1 is available. If Source 1 is not available, then the transfer switch will transfer to neutral. If the load circuit is connected to Source 1 and the contact is open, then a transfer Source 2 is prohibited.

37. Service Equipment Rated Transfer Switch

Provides the label “suitable for use as service equipment” and the features necessary to meet the requirements for the label. Includes service disconnect with visible indication and neutral assembly with removable link. **Feature 16B** or **16N** must be selected separately.

37A. Service Equipment Rated Transfer Switch Without Ground Fault Protection

Provides service equipment rating for an application that does not require ground fault protection.

37B. Service Equipment Rated Transfer Switch With Ground Fault Protection

Provides service equipment rating for an application that requires ground fault protection.

38. Steel Cover

Provides protection for a device panel as option 38a and protection for the controller as option 38b.

39. Distribution Panel

The distribution panel feature utilizes a panelboard design with bolt-on circuit breakers type EHD. Bolt-on breakers are designed to hold up to the changes in temperature and humidity that an industrial application calls for. (240/120 Vac single-phase systems only.)

39A. 225A With (2) 200A Feeders

39B. 300A With (3) 200A Feeders

39C. 400A With (4) 200A Feeders

Transfer Switches Standard and Optional Features

Automatic Transfer Switch Features

Feature Description (Continued)

41. Space Heater With Thermostat

Provides a space heater and adjustable thermostat. External control power is not required. Availability is dependent on transfer switch type.

41A. Space Heater With Thermostat—100 Watt

Provides 100-watt space heater with an adjustable thermostat.

41E. Space Heater With Thermostat—375 Watt

Provides 375-watt space heater with an adjustable thermostat.

42. Seismic Certification

Provides a seismic certified transfer switch with certificate for application that is seismic Zone 4 under the California Building Code (CBC), the Uniform Building Code (UBC) and BOCA, and International Building Code (IBC).

45. Load Sequencing Capability

Provides the capability for sequential closure of up to 10 addressable relays after a transfer. Each addressable relay provides (1) Form C contact. A single adjustable time delay between each of the relay closures is provided. Operates via a sub-network. Adjustable 1–120 seconds.

45A. Load Sequencing Contact

Provides (1) addressable relay.

45B. Load Sequencing Contact

Provides (2) addressable relays.

45C. Load Sequencing Contact

Provides (3) addressable relays.

45D. Load Sequencing Contact

Provides (4) addressable relays.

45E. Load Sequencing Contact

Provides (5) addressable relays.

45F. Load Sequencing Contact

Provides (6) addressable relays.

45G. Load Sequencing Contact

Provides (7) addressable relays.

45H. Load Sequencing Contact

Provides (8) addressable relays.

45I. Load Sequencing Contact

Provides (9) addressable relays.

45J. Load Sequencing Contact

Provides (10) addressable relays.

47. Transfer Modes for Closed Transition Transfer Switches

Provides available transition transfer modes for a closed transition transfer switch. Closed transition is a “make before break” transfer and retransfer scheme that will parallel (a maximum of 100 ms) Source 1 and Source 2 providing a seamless transfer when both sources are available. The closed transition feature includes permissible voltage difference frequency difference and synchronization time allowance set points. The phase angle difference between the two sources must be near zero for a permitted transfer. These are all programmable set points in the controller.

47C. Closed Transition With Default to In-Phase Transition With Default to Load Voltage Decay

Provides a closed transition transfer as the primary transfer mode. In the event Source 1 and Source 2 fail to synchronize within the permitted voltage difference, frequency difference, phase angle difference and time, then the controller defaults to the in-phase transition with default to load voltage decay operations as described in **Feature 32C** and **32B**. Adjustable frequency difference 0.0–0.3 Hz. Adjustable voltage difference 1–5% volts. Adjustable synchronization time allowance 1–60 minutes.

47D. Closed Transition

Provides a closed transition transfer as the primary transfer mode. Only under a fail-safe condition (i.e., loss of the connected source) will the controller transfer to the alternate source using the load voltage decay operation as described in **Feature 32B32B**. Adjustable frequency difference 0.0–0.3 Hz. Adjustable voltage difference 1–5% V.

47E. Closed Transition With Default to In-Phase Transition With Default to Time Delay Neutral

Provides a closed transition transfer as the primary transfer mode. In the event Source 1 and Source 2 fail to synchronize within the permitted voltage difference, frequency difference, phase angle difference and time, then the controller defaults to the in-phase transition with default to time delay neutral operation as described in **Features 32D** and **32A32B32A**. Adjustable frequency difference 0.0–0.3 Hz. Adjustable voltage difference 1–5 percent volts. Adjustable synchronization time allowance 1–60 minutes.

47F. Closed/Load Voltage Decay

ATC-800 controllers equipped with Feature Set 47F will perform a closed transition when both sources are synchronized in frequency, phase and voltage. Failure to synchronize will result in an open transition Time Delay Load Voltage Decay transfer. Time Delay Load Voltage Decay uses the load voltage measurements to sense back EMF that is generated when the transfer switch is in the Neutral position. It provides a delay in transfer in either direction if an unacceptable level is sensed as established by a customer programmed level. The transfer will not take place until the back EMF decays below the acceptable programmed level. This feature has a separate setting of enabling or disabling the operation. If disabled, the transfer switch will not delay in the Neutral position and will transfer between the sources as fast as possible. This feature is not available with the Time Delay Neutral Optional **Feature 32A**.

47G. Closed/Time Delay Neutral

ATC-800 controllers equipped with Feature Set 47F will perform a closed transition transfer when both sources are synchronized in frequency, phase and voltage. Failure to synchronize will result in an open transition Time Delay Neutral transfer. Time Delay Neutral provides a time delay in the transfer switch neutral position when both sources are open. This delay takes place when the load is transferred in either direction to prevent excessive in-rush currents due to out-of-phase switching of large motor loads.

48. Communication Modules

Provides communications modules for the ATC-300, ATC-600 and ATC-800 transfer switch controllers.

48A. INCOM

Communication (IPONI) Provides Taylor's proprietary INCOM protocol communications modules.

48D. Ethernet

Communication (PXG400 Gateway)

Translates Modbus RTU, QCPort or INCOM to Modbus TCP. The PXG400 Gateway includes embedded Web server monitoring of up to 64 connected devices. (Includes the IPONI with the ATC-600 and ATC-800 controllers.)

Automatic Transfer Switch Features

Feature Description (Continued)

48F. Modbus

Communication (MPONI)

Provides Modbus RTU protocol via communications module.

48R. Remote Annunciator

Provides remote monitoring of source availability, source position and test status for the ATC-600 and ATC-800 controllers. Operates via the controller sub-network.

48RAC. Remote Annunciator with Control

Provides remote monitoring and control via a color touch screen display for the ATC-300, ATC-600 and ATC-800 controllers. Operates using Modbus protocol (MPONI required for the ATC-600 and 800).

Option 51. Surge Protection Device

Two types of surge protection devices are used in Taylor automatic transfer switches. Both types meet the requirements for UL 1449 3rd Edition for surge suppression devices and are CE marked. The type CVX is used on Taylor wallmount ATS designs and the Taylor type SPD are used on floor-standing designs.

CVX

The CVX device features a Thermally Protected Metal Oxide Varistor technology and comes with high intensity LED phase status indicators.

SPD

The SPD features a Thermally Protected Metal Oxide Varistor technology. It comes with dual-colored protection status indicators for each phase and for neutral-ground protection mode. It comes with an audible alarm with silence button and a Form C contact.

An optional SPD with surge counter feature package is available. This provides six-digit surge counter with reset button.

51S1B. 50 kA—SPD standard source 1

51S2B. 80 kA—SPD standard source 1

51S3B. 100 kA—SPD standard source 1

51S4B. 120 kA—SPD standard source 1

51S5B. 160 kA—SPD standard source 1

51S6B. 200 kA—SPD standard source 1

51S7B. 250 kA—SPD standard source 1

51S8B. 300 kA—SPD standard source 1

51S9B. 400 kA—SPD standard source 1

51S1C. 50 kA—SPD standard with surge counter source 1

51S2C. 80 kA—SPD standard with surge counter source 1

51S3C. 100 kA—SPD standard with surge counter source 1

51S4C. 120 kA—SPD standard with surge counter source 1

51S5C. 160 kA—SPD standard with surge counter source 1

51S6C. 200 kA—SPD standard with surge counter source 1

51S7C. 250 kA—SPD standard with surge counter source 1

51S8C. 300 kA—SPD standard with surge counter source 1

51S9C. 400 kA—SPD standard with surge counter source 1

51SC8. Remote display panel (8 feet standard)

51SC12. Remote display panel (12 feet)

51SC4. Remote display panel (4 feet)

54. Front Access

54A. Front access cabinet available for all Magnum products. This option will add an additional pull section mounted on the side of the switch.

59a. Silver-Plated Bus

Silver-plated bus is a standard feature for all Magnum-based designs.

59b. Tin-Plated Bus

Tin-plated bus is available as an option for Magnum-based designs.

Glossary

With respect to their use in this document and as they relate to switch operation, the following terminology is defined:

Available—A source is defined as “available” when it is within its undervoltage/overvoltage/underfrequency/overfrequency (if applicable) set point ranges for the nominal voltage and frequency setting.

Fail-safe—A feature that prevents disconnection from the only available source and will also force a transfer or retransfer operation to the only available source.

Retransfer—Retransfer is defined as a change of the load connection from the secondary to primary source.

Source 1—is the primary source or normal source or normal power source or normal. (Except when Source 2 has been designated the “Preferred Source.”)

Source 2—is the secondary source or emergency source or emergency power source or emergency or standby or backup source. (Except when Source 2 has been designated the “Preferred Source.”)

Source 1—Failed or fails—Source 1 is defined as “failed” when it is outside of its undervoltage or overvoltage or underfrequency or overfrequency (if applicable) set point ranges for the nominal voltage and frequency setting.

Source 2—Failed or fails—Source 2 is defined as “failed” when it is outside of its undervoltage or overvoltage or under-frequency or overfrequency (if applicable) set point ranges for the nominal voltage and frequency setting for a time exceeding 0.5 seconds after the time delay emergency fail (TDEF) time delay expires.

Transfer—“Transfer” is defined as a change of the load connection from the primary to secondary source except when specifically used as “Transfer to Neutral.”

Transfer to Neutral—“Transfer to Neutral” is defined as when the load circuits are disconnected from both Source 1 and Source 2.

SEISMIC QUALIFIED



TEST CERTIFICATE OF SEISMIC WITHSTAND CAPABILITY

Taylor's equipment identified below was tested for seismic withstand capability and tested in accordance with the combined requirements specified in the International Building Code, California Building Code and the Uniform Building Code. As required by the codes, the equipment demonstrated its ability to function after the seismic tests. The seismic capability of the equipment exceeds the worst-case required levels, as illustrated in the figure below.

UL 1008 Low Voltage Transfer Switches— Wall Mounted (MCCB and Contactor Type)

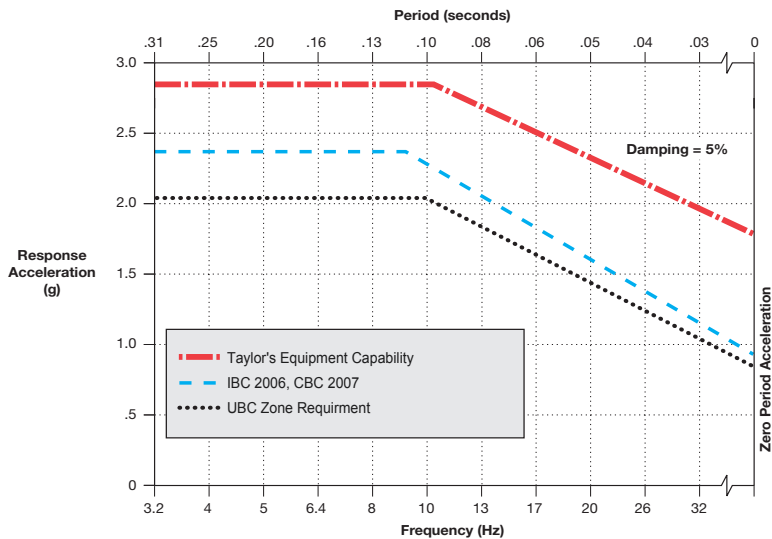

The frequency sweep tests revealed that the lowest equipment natural frequency is:

>3.2 Hz

Mostafa A. Ahmed

3RD PARTY TEST ENGINEER IN CHARGE



SEISMIC QUALIFIED



TEST CERTIFICATE OF SEISMIC WITHSTAND CAPABILITY

Taylor's equipment identified below was tested for seismic withstand capability and tested in accordance with the combined requirements specified in the International Building Code, California Building Code and the Uniform Building Code. As required by the codes, the equipment demonstrated its ability to function after the seismic tests. The seismic capability of the equipment exceeds the worst-case required levels, as illustrated in the figure below.

UL 1008 Low Voltage Transfer Switches—Floor Mounted (Magnum DS Breakers and Contactor Type)

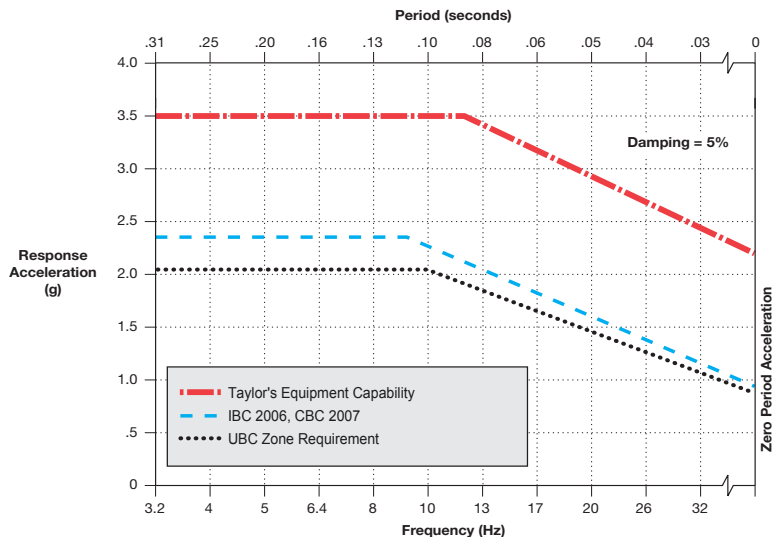

The frequency sweep tests revealed that the lowest equipment natural frequency is:

6.2 Hz

Mostafa A. Ahmed
3RD PARTY TEST ENGINEER IN CHARGE

