



EPA Certified / Stationary Emergency

OUTPUT POWER OPTIONS					STANDBY RATING		sKVA
Make	Voltage	Alternator	Phase	Hertz	kW/kVA	Amps	30% Voltage Dip
Stamford	600	UCI274G17	3	60	150/188	181	800
	277/480	UCI274G311	3	60	150/188	226	730
	120/208	UCI274G311	3	60	150/188	521	575
	120/240	UCI274G311	3	60	150/188	452	575
	120/240	UCI274G311	1	60	123/123	513	383
	120/240	UCI274G06	1	60	150/150	625	510
Marathon	600	431PSL6240	3	60	150/188	181	455
	277/480	431CSL6202	3	60	150/188	226	455
	120/208	431CSL6202	3	60	150/188	521	340
	120/240	431CSL6202	3	60	150/188	452	340
	120/240	431CSL6202	1	60	121/121	504	108
	120/240	431PSL6224	1	60	150/150	625	139
Marathon	277/480	431CSL6204	3	60	150/188	226	519
	120/208	431CSL6204	3	60	150/188	521	390
	120/240	431CSL6204	3	60	150/188	452	390
	120/240	431CSL6204	1	60	135/135	563	135



Engine Data

Manufacturer	Perkins
Model	1106D-E70TAG3
Aspiration	Turbocharged
EPA Tier	3
Charge Air Cooling System	Air-to-Air
Arrangement	Vertical Inline, 4-Cycle
Firing Order	1-5-3-6-2-4
Displacement: L (in. ³)	7.01 (427.78)
Bore: mm (in.)	105.00 (4.13)
Stroke: mm (in.)	135.00 (5.32)
Compression Ratio	16.8:1
BMEP: psi (kPa)	252.86 (1743.40)
Net Horsepower	232.36
Rated RPM	1800
Governor	Isochronous
Speed Regulation	±0.26%

Engine Liquid Capacity

Oil System: qt. (L)	18.49 (17.50)
Cooling Capacity: gal (L)	5.55 (21.00)

Engine Electrical

Electric Volts: DC	12
Cold Cranking Amps	925
Battery(s) Required	1

Fuel System

Fuel Injection Type	Electronic CRIN2
Fuel Pump Rate: gal/hr (L/hr)	104.61 (396.00)
Max Suction Head: in. H ₂ O (kPa)	-68.23 (-17.00)
Max Pressure Head: in. H ₂ O (kPa)	40.13 (10.00)
Recommended Fuel	Low Sulfur Diesel

Air Requirements

Air Filter(s) Type	Dry
Combustion Air Flow: CFM (m ³ /min)	540.32 (15.30)
Maximum Air Intake Restriction	
Clean: in. H ₂ O (kPa)	16.05 (4.00)
Dirty: in. H ₂ O (kPa)	32.11 (8.00)
Radiator Air Flow: CFM (m ³ /min)	9963.1 (282.1)

Exhaust System

Gas Temperature: °F (°C)	842.0 (450.0)
Gas Flow: CFM (m ³ /min)	1105.4 (31.3)
Max Back Pressure: in. H ₂ O (kPa)	60.20 (15.00)
Exhaust Outlet Size: in. (mm)	4.56 (115.90)

Sound Level

Open Unit Without Exhaust: dBA 3.2 ft (1M)	98.8
--	------

Filters and Quantity

Air Cleaner Quantity	1
Oil Filter(s) Quantity	1
Fuel Filter(s) Quantity	2

Fuel Consumption

At 100% of Power Rating: gal/hr (L/hr)	12.13 (45.90)
At 75% of Power Rating: gal/hr (L/hr)	11.17 (42.30)
At 50% of Power Rating: gal/hr (L/hr)	9.17 (34.70)
At 25% of Power Rating: gal/hr (L/hr)	6.29 (23.80)

Cooling System

Rejection to Charge Cooler: kW (BTUM)	37.6 (2138.3)
Rejection to Coolant & Oil: kW (BTUM)	76.8 (4367.5)
Coolant Flow: gal/min (L/min)	44.9 (170.0)

GENERAL GUIDELINES FOR DERATION: Altitude: Derate 0.5% per 100m (328 ft.) Elevation above 1000m (3279 ft.) Temperature: Derate 1.0% per 10°C (18°F) temperature above 25°C (77°F)

RATINGS: All three-phase units are rated at 0.8 power factor. All single-phase units are rated at 1.0 power factor.

125° RATINGS: 125° apply to installations served by a reliable utility source. The standby rating is applicable to varying loads for the duration of a power outage. There is no overload capability for this rating. Ratings are in accordance with ISO-3046/1, BS 5514, AS 2789, and DIN 6271. For limited running time and base load ratings consult the factory. The generator set manufacturer reserves the right to change the design or specifications without notice and without any obligation or liability whatsoever.

Alternator Data

Manufacturer	Stamford	
Type	PMG	
Insulation Class	NEMA H	
Temperature Rise	125°C Standby	
Hertz	60	
RPM	1800	
Amortisseur Windings	Full	
CFM Cooling Required	1308	
Voltage Regulator	MX341	MX321
Sensing	Single Phase	Three Phase
Voltage Regulation	1.0%	0.50%

Features

- BS EN 60034, BS5000, VDE 0530, NEMA MG1-32, IEC34, CSA C22.2-100, and AS1359 compliant
- IP23 enclosure
- Dynamically balanced to exceed BS6861:Part 1 Grade 2.5 vibration standard
- Quality assurance to BS EN ISO 9001
- Self-ventilated and Drip proof construction
- Two-thirds pitch stator and skewed rotor
- Heavy duty bearings
- Fully guarded
- Overexcitation protection
- Under frequency protection
- Analog input
- Overvoltage protection
- Paralleling compatible

Alternator Data

Manufacturer	Marathon	
Type	PMG	
Insulation Class	NEMA N	
Temperature Rise	125°C Standby	
Hertz	60	
RPM	1800	
Amortisseur Windings	Full	
CFM Cooling Required	1208	
Voltage Regulator	DVR2400	PM500
Sensing	Three Phase	Three Phase
Voltage Regulation	0.25%	0.25%

Features

- NEMA MG1-32, BS5000, and IEC 34-1 compliant; CE & CSA Certified and UL Listed
- Self-ventilated and drip proof construction
- Two-thirds pitch stator and skewed rotor
- Wet wound, epoxied field windings
- Designed to withstand overspeeds of up to 125%
- Hybrid analog/digital voltage regulator
- Under frequency protection
- Under frequency indication light
- Less than one cycle response time
- Over excitation protection
- Over excitation indication light
- Easy access front-panel adjustments
- Over voltage protection shutdown

Control Panels



DeepSea 7310 MKII

Simultaneous Use of RS232 & RS485
 Modbus RTU Support
 Fully Configurable Using USB, RS232 & RS485
 IP65 Rating
 6 Programmable Inputs & 8 Outputs
 UL & cUL Listed and CE Certified

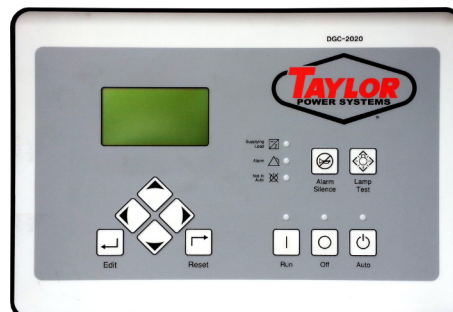

Basler DGC2020

SAE J1939 Engine ECU Communications
 4 Programmable Inputs & 10 Outputs
 Modbus Communications With RS485
 UL Recognized, CSA & CE Certified
 IP 54 Front Panel Rating
 NFPA 110 Level 1 Compatible
 Manual Override Keyswitch
 DGC2020HD Variant Available



Taylor Analog

Automatic CANBUS Engine Control
 Gauge Zeroing on Shutdown
 Auto-Off-Manual Control Switch
 Oil Pressure, Water Temperature, Battery Voltage and RPM Gauges
 AC Voltage, Frequency, Percent of Load, and Run-Time Metering
 LED Status Lights

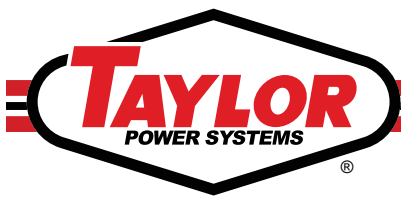

Standard Features:

Warranty

2 Year Standard
5 Year Comprehensive

- | | |
|------------------------------------|------------------------|
| Heavy Duty Steel Base | Battery Charger |
| Vibration Isolators | Block Heater |
| Oil Drain Valve with Extension | Factory Powder Coating |
| Coolant Drain Kit | Factory Load Test |
| High Ambient Unit Mounted Radiator | Owner's Manual |

Controller Options

DGC2020HD Controller
Fiber Optic Ethernet (DGC2020HD)
RS-232 Port & Generator Protection (DGC2020)
Flush or Surface Mount Remote Annunciator
Remote Mount Break Glass E-Stop Switch

Miscellaneous Options:

- | | |
|------------------------|-------------------------|
| Generator Strip Heater | Pad Type Battery Heater |
| Spring Isolators | Battery Heater Blanket |
| Line Circuit Breaker | Oil Pan Heater |

Open Unit

Options:

- Radiator Duct Flange
- Flex Exhaust
- Critical Silencer
- Sub-Base Fuel Tank

Overall Size: 98"L x 35"W x 62"H
 Approximate Weight: 3,500 lbs.

Note: Dimensions and weights reflect standard open unit with no options and are subject to change.

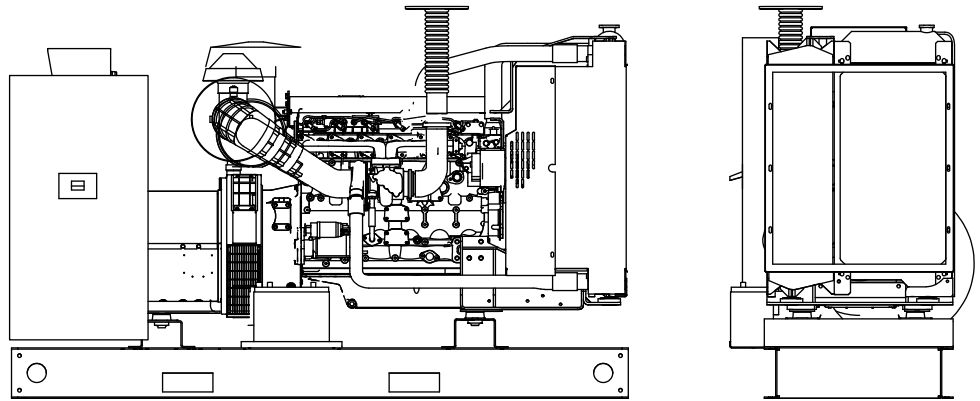

Standard Enclosed Unit

Options:

- Sound Attenuated Enclosure
- Load Center, Lights & GFI Receptacle
- Sub-Base Fuel Tank

Overall Size: 136"L x 60"W x 68"H
 Approximate Weight: 5,500 lbs.

Note: Dimensions and weights reflect standard enclosed unit with no options and are subject to change.

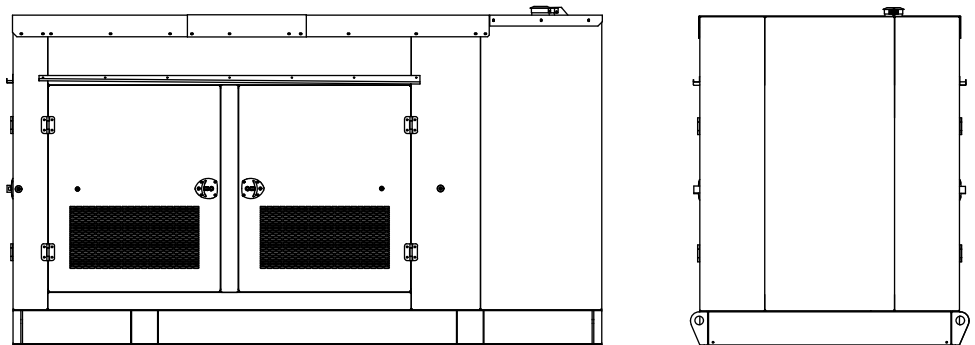

Note: The above drawings are provided for reference only and should not be used for planning installation. Contact your local distributor for more information.