

TAYLOR[®]

POWER SYSTEMS

Model: V180CD1

Unit Ratings:

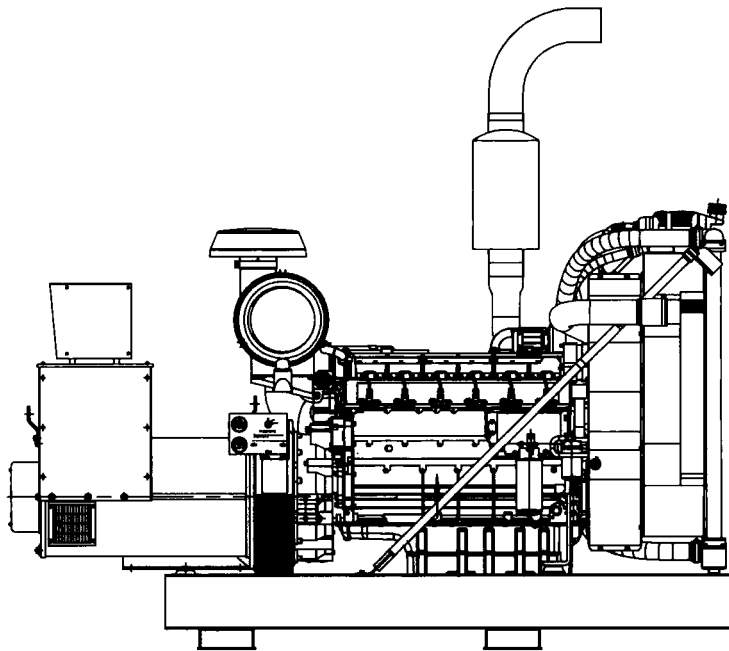

	60Hz
Standby: kw/kva	180
Prime: kw/kva	162

Alternator Ratings at 1.0 Power Factor

Features

- **Single source responsibility for the generator set and accessories.**
- **Prototype and production tested to insure one step load acceptance per NFPA 110.**
- **Two year limited warranty on generator sets and accessories.**
- **Unit conforms to CSA, NEMA, EGSA, ANSI and other standards.**
- **EPA mobile-off highway certified engine**
- **Electronic Isochronous Governor**
- **Analog control system with an ECU-CAN74 providing metering and monitoring.**
- **Heavy duty 4 cycle industrial engine for reliability and fuel efficiency.**
- **Brushless rotating field generator with class H insulation.**
- **Heavy duty steel base with integral vibration isolators.**

APPLICATION & ENGINEERING DATA

ENGINE

Engine Specifications	60 Hz	50 Hz
Manufacturer	VOLVO	
Engine, model, type	TAD721GE 4-CYCLE Tier 2 Air to air intercooled	
Cylinder arrangement	6 vertical, in-line	
Displacement, cu. in. (L)	436.3 (7.15)	
Bore and stroke, in. (mm)	4.25 (108) x 5.12 (130)	
Compression ratio	18.1:1	
Piston speed, ft/sec. (m/sec)	25.7 (7.8)	21.4 (6.5)
Rated rpm	1800	1500
Max. power at rated rpm, hp (kw)	277 (204)	249 (183)
Cylinder head material	Cast iron	
Crankshaft material	Forged steel	
Governor type	Heinzmann / EDC 4	
Air cleaner type, all models	Dry paper element w/air rest. indicator	
Injection Pump Type	Single Bosch w/ EDC4 actuator	

EXHAUST

Exhaust System	60 Hz	50 Hz
Exhaust flow at rated kW, cfm (m ³ /min.)	1451 (41.1)	1197 (39.9)
Exhaust temperature at rated kW, dry exhaust, °F (°C)	921 (494)	1004 (540)
Maximum allowable back pressure, in. wc (kPa)	28.1 (7 KPA)	20.1 (5 KPA)
Heat Rejected to Exhaust: BTU/min	9440	8132

ENGINE ELECTRICAL

Engine Electrical System	60 Hz	50 Hz
Battery charging alternator: Ground (negative/positive).....	Negative	
Volts (DC).....	24	
Ampere rating.....	55	
Starter motor rated voltage (DC)	24	
Recommended battery cold cranking amps (CCA) rating for +20° C	400	
Quantity of batteries	2	
Battery voltage (DC)	24	

FUEL

Fuel System	60 Hz	50 Hz
Total Fuel Flow U.S. gal/hour	119	95
Feed Pump Pressure psi (kPa)	72.5 (500)	
Feed Pump Max. Suction Head ft. (m)	4.9 (1.5)	
Injection Timing std.	4° B.T.D.C.	
Fuel filters	1 Spin on Type and 1 Fuel Pre-Filter W/ water separator	
Recommended fuel	#2 diesel	

FUEL CONSUMPTION

Fuel Consumption	60 Hz	50 Hz
Diesel, gph (Lph) at % of load		
100%	12.7 (48)	11.9 (45)
75%	9 (34)	8.7 (33)
50%	5.8 (22)	5.8 (22)

COOLING

Cooling System	60 Hz	50 Hz
Coolant Capacity U.S. gal. (liters) radiator with hoses	7.21 (27.3)	
Coolant Flow U.S. gal/s (liter/s)	.95 (3.6)	.79 (3)
Fan Power Consumption hp (kw)	10 (7.4)	6 (4.4)
Fan Diameter in. (mm)	30.31 (770)	
Heat rejected to cooling water at rated kW, dry exhaust Btu/min.	5289	4663
Water pump type	Belt Driven Efficient Cooling Pump	
Air Consumption at Rated rpm cfm (m ³ /min.)	530 (15)	391 (11)

LUBRICATION

Lubricating System	60 Hz	50 Hz
Type	FULL PRESSURE W/ INTEGRATED FULL FLOW OIL COOLER	
Oil pan capacity with filter, U.S. GAL (L)	8.9 (34)	
Oil filter, quantity, type	1 FULL FLOW DISPOSABLE	
Oil cooler	full flow oil cooler	
Oil Pressure at Rated Speed psi	64	58

ANALOG CONTROL PANEL

- **Taylor Power Systems Analog Auto Start Control Panel.** The panel is equipped with AC Voltmeter, AC Frequency Meter, Percent of Load Meter, Running Time Meter, Control Toggle Switch with Off/Auto/Manual positions, and ECU-CAN74 engine control with specific safety shutdown lights.
- **Separate Oil Pressure and Water Temperature Gauge Located on Generator Set.**
- **Taylor Power Systems also supplies a manual key override by-pass switch that allows you to start the generator manually in the event of control systems failure.**

ECU-CAN74 FEATURES

- **Engine Started LED**
- **Overspeed Shutdown LED**
- **Overcrank Shutdown LED**
- **High Water Temperature Shutdown LED**
- **Low Oil Pressure Shutdown LED**

The ECU automatically cranks, starts, and monitors the engine for Overcrank, Overspeed, High Water Temperature, and Low Oil Pressure. A built in speed switch uses a magnetic pickup to monitor engine speed for crank disconnect and overspeed. The bypass timer/logic assures Low Oil Pressure and High Water Temperature override during the crank period and an additional adjustable period after crank disconnect. The ECU monitors the Magnetic Pickup signal for problems during both cranking and running. If a problem is detected the engine will shutdown and Overcrank and Overspeed LED's will both turn on.

GENERATOR SPECIFICATIONS

Taylor Power Systems uses Full Output Rated 4 Lead design Single Phase Generators, which provide superior motor starting, and generator efficiency.

STANDARDS

UC224 and UC274 industrial generators meet the requirements of BS5000, VDE0530, UTE5100, NEMA MG1-22, CEMA, IEC34-1, CSA22.2 AND AS1359.

EXCITATION SYSTEMS

With the self-excited systems the main stator provides power via the automatic voltage regulator (AVR) to the exciter stator. The high efficiency semiconductors of the (AVR) ensure positive build up from initial low levels of residual voltage.

The exciter rotor output is fed to the main rotor through a full wave bridge rectifier. The rectifier is protected by a surge suppressor against surges caused, by short circuit.

INSULATION / IMPREGNATION

The insulation system is Class 'H'.

All wound components are impregnated with materials and processes designed specifically to provide protection against the harsh environments encountered in generator applications. Varnishes and resins are selected and developed to provide the high build required for static windings and the high mechanical strength required for rotating components.

WINDINGS & ELECTRICAL PERFORMANCE

All generator stators are wound to 2/3 pitch. This eliminates triplen (3rd, 9th, 15th...) harmonics on the voltage waveform and is found to be the optimum design for trouble-free supply of non linear loads. The 2/3 pitch design avoids excessive neutral currents, sometimes seen with higher winding pitches, when in parallel with the mains.

A fully connected damper winding reduces oscillations during paralleling. This winding, with 2/3 pitch and carefully selected pole and tooth designs, ensures very low waveform distortion.

TELEPHONE INTERFERENCE

THF (as defined by BS4999 Part 40) is better than 2%. TIF (as defined by ASA C50.12) is better than 50.

RADIO INTERFERENCE

The absence of brushgear and the high quality AVR ensure low levels of interference with radio transmissions.

Additional RFI suppression may be supplied if required.

ENCLOSURE

IP22 (NEMA 1) is standard for all industrial generators Protection to IP23 (60 degrees from vertical) is available as an option at reduced ratings (5% derate).

Inlet air filters are available as an option on all generators, at reduced ratings (5% derate).

SHAFT

All generator rotors are dynamically balanced to better than BS6861: Part 1 Grade 2.5 for minimum vibration in operation.

QUALITY ASSURANCE

Generators are manufactured using production procedures having a quality assurance level to BS EN (ISO9001).

STANDARD FEATURES AND ACCESSORIES

Standard Features

- Heavy duty steel base
- Vibration isolators
- Battery
- Battery rack
- Battery cables
- Water jacket heater
- Owners manual
- Spark arresting muffler
- Flexible fuel lines
- Electronic Isochronous Governor
- PMG Exciter

Accessories

- Generator strip heater
- Line circuit breaker
- Automatic transfer switch
- Elevated Base

Accessories

- Exhaust silencer
- Sub-base fuel tank
- Above ground fuel tank
- Oil pan heater
- Battery heater
- Battery charger

WEIGHTS AND DIMENSIONS

V180CD1

Overall Size, L x W x H, in.: (104.25" x 45" x 94.5")

Weight Est. (wet): 3890 Lbs.

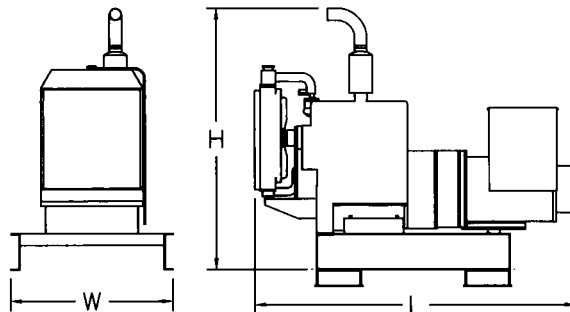

Note: This drawing is provided for reference only and should not be used for planning installation. Contact your local distributor for more detailed information.

Availability is subject to change without notice. Taylor Power Systems reserves the right to change the design or specifications without notice and without any obligation or liability whatsoever. Availability can be determined by contacting Taylor Power Systems.

TAYLOR POWER SYSTEMS

461 Hwy. 49S
Richland, Mississippi 39218
Phone (601)-932-5674
Toll Free 1-800-367-7639
FAX (601)-932-4028
Web Site www.taylorpower.com

DISTRIBUTED BY: