

Ratings Range — 60 Hertz Operation

Standby:	kW	1480-1600
	kVA	1850-2000
Prime:	kW	1340-1450
	kVA	1675-1813

Throughout its 80 year history, **Taylor Machine Works**, which manufactures heavy machinery for industries worldwide, has maintained a reputation of having unparalleled products with service to match. **Taylor Power Systems** is no different!

In the early 1980's Taylor Machine Works created Taylor Power Systems to distribute industrial engines and manufacture generator sets offering diesel powered 9 kW to 2000 kW and gaseous powered 30 kW to 400 kW. Taylor Power Systems provides quality standby and prime generator sets in stationary or mobile configurations for a wide variety of applications for example the Healthcare and Telecommunications Industries, Public Utilities, Federal, State and Local Government agencies, Educational and Financial Institutions as well as Agricultural.

Taylor Power Systems is your 21st Century Power Source!

- Single source responsibility for the generator set and accessories.
- Prototype and production tested to insure one step load acceptance per NFPA 110.
- Two year limited warranty on generator sets and accessories. Extended warranties also available.
- Unit conforms to CSA, NEMA, EGSA, ANSI and other standards.
- Heavy duty 4 cycle industrial engine for reliability and fuel efficiency.
- Brushless rotating field generator with class H insulation.
- Heavy duty steel base with integral vibration isolators.
- EPA Tier 2 Certified for Stationary Emergency Standby use only.

Genset Ratings

Genset Model Number	Alternator	Voltage L-N / L-L	Phase	Hertz	130° Rise Standby Rating		105° Rise Prime Rating	
					kW / kVA	Amps	kW / kVA	Amps
TD1600	743RSL4052	220/380	3	60	1480/1850	2811	1340/1675	2545
		240/416	3	60	1600/2000	2776	1450/1813	2515
		277/480	3	60	1600/2000	2406	1450/1813	2180

RATINGS: All three-phase units are rated at 0.8 power factor. All single-phase units are rated at 1.0 power factor.
 STANDBY RATINGS: Standby ratings apply to installations served by a reliable utility source. The standby rating is applicable to varying loads for the duration of a power outage. There is no overload capability for this rating. Ratings are in accordance with ISO-3046/1, BS 5514, AS 2789, and DIN 6271.
 PRIME POWER RATINGS: Prime power ratings apply to installations where utility power is unavailable or unreliable. At varying load the number of generator set operating hours is unlimited. A 10% overload capacity is available for one hour in twelve. Ratings are in accordance with ISO-8528/1, overload power in accordance with ISO-3046/1, BS5514, AS2789, and DIN 6271. For limited running time and base load ratings consult the factory. The generator set manufacturer reserves the right to change the design or specifications without notice and without any obligation or liability whatsoever.
 GENERAL GUIDELINES FOR DERATION: Altitude: Derate 0.5% per 100m (328 ft.) elevation above 1000m (3279 ft.) Temperature: Derate 1.0% per 10°C (18°F) temperature above 40°C (104°F).

Generator Controller Options



Digital Control Panel

- Integrated engine-genset control, protection, and metering
- Microprocessor allows for exact measurement, setpoint adjustment, and timing functions
- Front panel 3 position controls and indicators enable quick and simple operation
- Emergency stop push button and an Alarm Horn with silence button
- A wide temperature-range liquid crystal display (LCD) with backlighting
- SAE J1939 Engine ECU communications
- Multilingual capability
- Remote RS-485 communications for Optional RDP-110 Remote Annunciator
- 4 programmable contact inputs and 10 contact outputs (2 A/c rated)
- Modbus Communications with RS-485, Battery Backup for Real Time Clock, UL recognized, CSA certified, CE approved, HALT (Highly Accelerated Life Tests) tested, IP 54 Front Panel rating with integrated gasket. and NFPA 110 Level 1 Compatible.



Analog Controller

- Monitor AC voltage, AC frequency, percent of load and, run time/hour meter
- Overspeed, overcrank, low oil pressure, and high coolant temperature indicators
- Green LED indication of engine running
- Control switch for local and remote starting with 3 position run/off/remote switch
- Emergency by-pass key switch gauge
- Mechanical oil pressure gauge
- Coolant temperature gauge

Alternator Specifications

Manufacturer	Marathon	<ul style="list-style-type: none"> • NEMA MG1, IEEE, AND ANSI standards compliance for temperature and motor starting. • Sustained short-circuit current of the rated current for up to 10 seconds. • Sustained short-circuit current enabling downstream circuit breakers to trip without collapsing the alternator field. • Self-ventilated and dripproof construction. • Superior voltage waveform from a two-thirds pitch stator and skewed rotor. • Linkboards • Optimized Electrical Design • Enhanced Ventilation • Fully Guarded • Heavy Duty Bearings
Type	Ext. Voltage Regulated, Brushless	
Gen Frame	360 MAGNAMAX	
Insulation	NEMA	
Material	Class H	
Temperature Rise	130 °C, Standby	
Hertz	60	
Phase	3	
RPM	1800	
Exciter	Rotating	
# Leads	12 Reconnectable or 4 Single Phase	
PF	0.8	
Ambient	40°C	
Coupling Single Bearing	Flexible	
Amortisseur Windings	Full	
Cooling Air Volume	250 CFM	
Peak Motor Starting	35% Voltage Dip, 5500 skVA	
Voltage Regulation no-load and full-load	3 Phase Sensing 1/2%	

STANDARD FEATURES

- Heavy Duty Steel Base
- Vibration Isolators
- Oil Drain Valve with Extension
- Battery Rack
- Battery Cables
- High Ambient Unit Mounted Radiator
- Battery Charging Alternator
- Factory Paint
- Factory Test Prior to Shipment
- 2 Year Warranty
- Owners Manual

AVAILABLE ACCESSORIES

OPEN UNIT

- Narrow Skid Base
- Radiator Duct Flange
- Ship Loose Flex Exhaust
- Ship Loose Critical Silencer

ENCLOSED UNIT

- Wide Skid Base
- Standard Enclosure With Internal Silencer
- Sound Attenuated Enclosure With Silencer
- Load Center With Lights and GFI Receptacle
- Sub-Base Fuel Tank

CONTROLLER

- DGC2020 Control Panel
- DGC2020 Control Panel with Modem
- DGC2020 with Generator Protection
- DGC2020 with Modem and Generator Protection
- Flush or Surface Mount Remote Annunciator
- Remote Mount Break Glass E-Stop Switch
- Analog Control Panel

MISCELLANEOUS

- Flexible Fuel Lines
- Coolant Drain Kit
- Water Jacket Heater
- Oil Pan Heater
- Generator Strip Heater
- Battery
- Battery Charger
- Pad Type Battery Heater
- Battery Heater Blanket with Thermostat
- Line Circuit Breaker

WARRANTY

- 3 Year Warranty
- 5 Year Warranty

APPROVALS AND LISTINGS

- UL Standard 2200

WEIGHTS AND DIMENSIONS

OVERALL SIZE, L x W x H,: 252 in. x 87.9 in. x 101.8 in.
WEIGHT: 31600 lbs.
Note: Dim and weights reflect standard open unit with no options

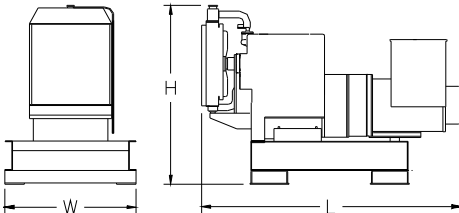

Note: This drawing is provided for reference only and should not be used for planning installation. Contact your local distributor for more detailed information.

DISTRIBUTED BY: