

TAYLOR[®]

POWER SYSTEMS

Model: **P140CD1**

Unit Ratings:

	60Hz
Standby: kw/kva	140
Prime: kw/kva	126

Alternator Ratings at 1.0 Power Factor

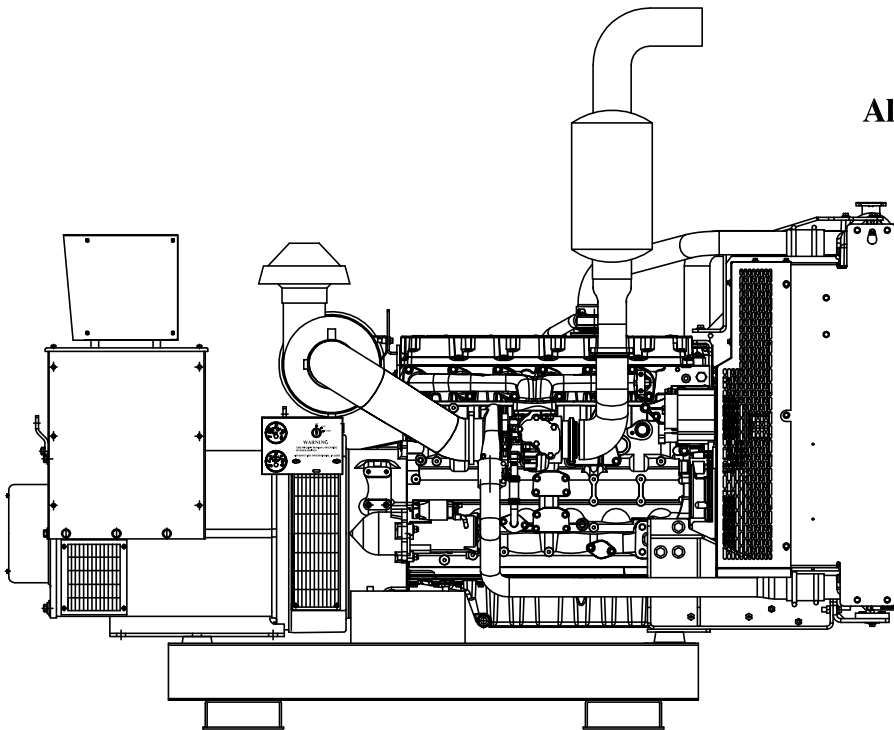

Features

- Single source responsibility for the generator set and accessories.
- Prototype and production tested to insure one step load acceptance per NFPA 110.
- Two year limited warranty on generator sets and accessories.
- Unit conforms to CSA, NEMA, EGSA, ANSI and other standards.
- Electronic Isochronous Governor
- Analog control system with an ECU-CAN74 providing metering and monitoring.
- Heavy duty 4 cycle industrial engine for reliability and fuel efficiency.
- Brushless rotating field generator with class H insulation.
- Heavy duty steel base with integral vibration isolators.
- EPA Tier 3 Certified Engine

APPLICATION & ENGINEERING DATA

ENGINE

Engine Specifications	60 Hz	50 Hz
Rated rpm	1800	1500
Manufacturer	Perkins	
Engine, model, type	1106D—E66TAG2 4 Cycle Turbocharged and Air Charge Cooled	
Cylinder arrangement	6 vertical, in-line	
Displacement, cu. in. (L)	402.8 (6.6)	
Bore and stroke, in. (mm)	4.1 (105) x 5.0 (127)	
Compression ratio	16.3:1	
Piston speed, ft/sec. (m/sec)	25 (7.62)	20.8 (6.35)
Max. power at rated rpm, hp (kw)	216.7 (166.6)	181.0 (135.0)
Combustion air flow, ft ³ /min.	445	339
Direction of Rotation	Clockwise	
Firing Order	1 5 3 6 2 4	
Max. Air Intake Restriction kPa	5 kPa	
—Clean Filter	8 kPa	
—Dirty Filter	Paper Element	
—Air Filter Type		

EXHAUST

Exhaust System	60 Hz	50 Hz
Exhaust flow at rated kW, cfm (m ³ /min.)	1048.8 (29.7)	918.2 (26.0)
Exhaust gas temperature (max.) in manifold after turbocharger °F(°C)	818.6 (437)	
Maximum allowable back pressure, in. Hg (kPa)	91.5 in. Hg (12.2 kPa)	63.8 in. Hg (8.5 kPa)
Exhaust outlet internal Diameter	90mm (3.5 in.)	

ENGINE ELECTRICAL

Engine Electrical System	
Battery charging alternator:	
TYPE.....	DENSO A127i
Volts (DC).....	12
Ampere rating.....	100
Starter motor:	
TYPE.....	DENSO P95
Volts (DC).....	12
Power.....	3kw
Number of teeth on flywheel	126
Battery voltage (DC)	12

FUEL

Fuel System	
Injectors	Electronic
Fuel Pump	CR200
Max. Fuel Flow	1.5 Liters per min.
Max. Suction Head at Engine Fuel Pump Inlet	4.35 psi
Max. Static Pressure Head	87 psi
Fuel Temp. at Engine Fuel Pump Inlet	176° F
Fuel Type	#2 Diesel

FUEL CONSUMPTION

Fuel Consumption	60 Hz	50 Hz
Diesel, gph (Lph) at % of load		
100%	11.5 (43.5)	8.7 (32.9)
75%	8.8 (33.3)	6.9 (26.1)
50%	6.6 (24.9)	4.9 (18.5)

COOLING

Cooling System	60 Hz	50 Hz
Max. Top Tank Temperature °F (°C)	233.6 (112)	
Engine Coolant Capacity Not including Radiator (L)	9.5	
Engine jacket water flow, gpm (Lpm)	45 (170)	37 (140)
Thermostat operation range	85 to 95 °C 185 to 203 °F	
Coolant Pump Method of Drive	gears	
Fan diameter, including blades, in. (mm)	24 (610)	
Power to Cooling Fan	8 kw	4.5 kw
Max. Permissible External System Resistance discharge side of rad., in. LBF in ² (kPa)	5.0 (35)	
Power to Coolant	74.9 kw	65.5 kw
Power to Radiation	13 kw	15.3 kw

LUBRICATION

Lubricating System	
Maximum total System Capacity	16.5 liters (17.4 quarts)
Oil Pressure at Max. Speed	65.26 psi (450 kPa)
Relief Valve Opening Pressure	62.4 psi (430 kPa)
Max. Continuous Oil Temp.	125°C

ANALOG CONTROL PANEL

- Taylor Power Systems Analog Auto Start Control Panel. The panel is equipped with AC Voltmeter, AC Frequency Meter, Percent of Load Meter, Running Time Meter, Control Toggle Switch with Off/Auto/Manual positions, and ECU-CAN74 engine control with specific safety shutdown lights.
- Separate Oil Pressure and Water Temperature Gauge Located on Generator Set.
- Taylor Power Systems also supplies a manual key override by-pass switch that allows you to start the generator manually in the event of control systems failure.

ECU-CAN74 FEATURES

- Engine Started LED
- Overspeed Shutdown LED
- Overcrank Shutdown LED
- High Water Temperature Shutdown LED
- Low Oil Pressure Shutdown LED

The ECU automatically cranks, starts, and monitors the engine for Overcrank, Overspeed, High Water Temperature, and Low Oil Pressure. A built in speed switch uses a magnetic pickup to monitor engine speed for crank disconnect and overspeed. The bypass timer/logic assures Low Oil Pressure and High Water Temperature override during the crank period and an additional adjustable period after crank disconnect. The ECU monitors the Magnetic Pickup signal for problems during both cranking and running. If a problem is detected the engine will shutdown and Overcrank and Overspeed LED's will both turn on.

GENERATOR SPECIFICATIONS

Taylor Power Systems uses Full Output Rated 4 Lead design Single Phase Generators, which provide superior motor starting, and generator efficiency.

STANDARDS

UC224 and UC274 industrial generators meet the requirements of BS5000, VDE0530, UTE5100, NEMA MG1-22, CEMA, IEC34-1, CSA22.2 AND AS1359.

EXCITATION SYSTEMS

With the self-excited systems the main stator provides power via the automatic voltage regulator (AVR) to the exciter stator. The high efficiency semiconductors of the (AVR) ensure positive build up from initial low levels of residual voltage.

The exciter rotor output is fed to the main rotor through a full wave bridge rectifier. The rectifier is protected by a surge suppressor against surges caused, by short circuit.

INSULATION / IMPREGNATION

The insulation system is Class 'H'.

All wound components are impregnated with materials and processes designed specifically to provide protection against the harsh environments encountered in generator applications. Varnishes and resins are selected and developed to provide the high build required for static windings and the high mechanical strength required for rotating components.

WINDINGS & ELECTRICAL PERFORMANCE

All generator stators are wound to 2/3 pitch. This eliminates triplen (3rd, 9th, 15th...) harmonics on the voltage waveform and is found to be the optimum design for trouble-free supply of non linear loads. The 2/3 pitch design avoids excessive neutral currents, sometimes seen with higher winding pitches, when in parallel with the mains.

A fully connected damper winding reduces oscillations during paralleling. This winding, with 2/3 pitch and carefully selected pole and tooth designs, ensures very low waveform distortion.

TELEPHONE INTERFERENCE

THF (as defined by BS4999 Part 40) is better than 2%. TIF (as defined by ASA C50.12) is better than 50.

RADIO INTERFERENCE

The absence of brushgear and the high quality AVR ensure low levels of interference with radio transmissions.

Additional RFI suppression may be supplied if required.

ENCLOSURE

IP22 (NEMA 1) is standard for all industrial generators Protection to IP23 (60 degrees from vertical) is available as an option at reduced ratings (5% derate).

Inlet air filters are available as an option on all generators, at reduced ratings (5% derate).

SHAFT

All generator rotors are dynamically balanced to better than BS6861: Part 1 Grade 2.5 for minimum vibration in operation.

QUALITY ASSURANCE

Generators are manufactured using production procedures having a quality assurance level to BS EN (ISO9001).

STANDARD FEATURES AND ACCESSORIES

Standard Features

- Heavy duty steel base
- Vibration isolators
- Battery
- Battery rack
- Battery cables
- Battery Charger
- Water jacket heater
- Owners manual
- Spark arresting muffler
- Flexible fuel lines
- Electronic Isochronous Governor
- PMG Exciter

Accessories

- Generator strip heater
- Line circuit breaker
- Automatic transfer switch
- Elevated Base

Accessories

- Exhaust silencer
- Sub-base fuel tank
- Above ground fuel tank
- Oil pan heater
- Battery heater

WEIGHTS AND DIMENSIONS P140CD1

Overall Size, LxWxHxA, in.: (94" x 40" x 55.5" x 76")

Weight (wet): 2880 Lbs.

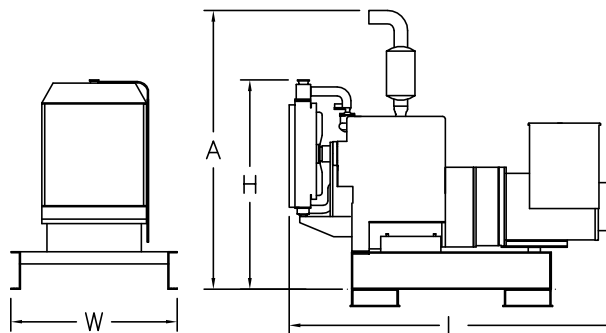

Note: This drawing is provided for reference only and should not be used for planning installation. Contact your local distributor for more detailed information.

Availability is subject to change without notice. Taylor Power Systems reserves the right to change the design or specifications without notice and without any obligation or liability whatsoever. Availability can be determined by contacting Taylor Power Systems.

TAYLOR POWER SYSTEMS

461 Hwy. 49S

Richland, Mississippi 39218

Phone (601)-932-5674

Toll Free 1-800-367-7639

FAX (601)-932-4028

Web Site www.taylorpower.com

DISTRIBUTED BY: