

TAYLOR[®]

POWER SYSTEMS

Model: DS65

Ratings Range:

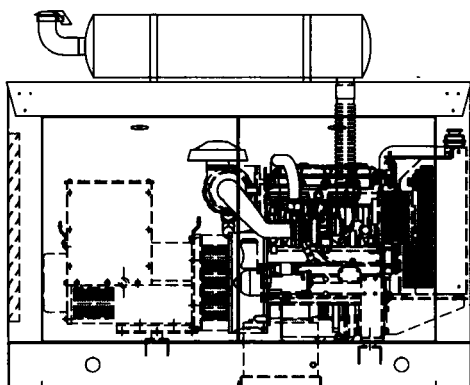

DRAWING DEPICTS UNIT WITH OPTIONAL EQUIPMENT

Features

- **Single source responsibility for the generator set and accessories.**
- **Prototype and production tested to insure one step load acceptance per NFPA 110.**
- **Two year limited warranty on generator sets and accessories.**
- **Unit conforms to CSA, NEMA, EGSA, ANSI and other standards.**
- **Microprocessor based control system providing digital metering and monitoring.**
- **Heavy duty 4 cycle industrial engine for reliability and fuel efficiency.**
- **Brushless rotating field generator with class H insulation.**
- **Heavy duty steel base with integral vibration isolators.**

	50Hz	60Hz
Standby: kw	46.5 - 52	49.2 - 65
kva	58 - 65	61.5 - 81.25
Prime: kw	41.6 - 47	45.6 - 58
kva	52 - 58.75	57 - 72.5

Generator	Voltage	PH	Hz	125°C Rise		105°C Rise	
				Standby kW/kVA	Amperes	Prime kW/kVA	Amperes
UCI224E311	277/480	3	60	60/75	90	54.5/68.1	82
	139/240	3	60	60/75	181	54.5/68.1	164
	254/440	3	60	56/70	92	52/65	85
	127/220	3	60	56/70	184	52/65	171
	240/416	3	60	54/67.5	94	50/62.5	87
	120/208	3	60	54/67.5	188	50/62.5	174
	120/240	3	60	54/67.5	163	50/62.5	151
	219/380	3	60	49.2/61.5	94	45.6/67	95
	120/240	1	60	45/45	188	42/42	175
	254/440	3	50	46.5/58	76	41.6/52	68
	127/220	3	50	46.5/58	152	41.6/52	137
	120/208	3	50	48/60	167	42.4/53	147
	240/415	3	50	48/60	84	42.4/53	74
	219/380	3	50	48/60	91	42.4/53	81
	110/190	3	50	48/60	183	42.4/53	161
	110/220	1	50	40/40	182	35.5/35.5	161
UCI224F311	277/480	3	60	65/81.25	98	58/72.5	87
	139/240	3	60	65/81.25	196	58/72.5	175
	254/440	3	60	65/81.25	107	58/72.5	95
	127/220	3	60	65/81.25	213	58/72.5	190
	240/416	3	60	65/81.25	113	58/72.5	101
	120/208	3	60	65/81.25	226	58/72.5	201
	120/240	3	60	65/81.25	196	58/72.5	175
	219/380	3	60	61/76.25	124	54/67.5	103
	120/240	1	60	56/56	233	50/50	208
	254/440	3	50	52/65	85	47/58.75	77
	127/220	3	50	52/65	171	47/58.75	154
	120/208	3	50	52/65	181	47/58.75	163
	240/415	3	50	52/65	91	47/58.75	82
	219/380	3	50	52/65	99	47/58.75	89
	110/190	3	50	52/65	198	47/58.75	179
	110/220	1	50	48.5/48.5	220	43.5/43.5	198
UCI224E06	120/240	1	60	50/50	208	47.3/47.3	197
UCI224F06	120/240	1	60	60/60	250	56.9/56.9	237

RATINGS: All three-phase units are rated at 0.8 power factor. All single-phase units are rated at 1.0 power factor.

STANDBY RATINGS: Standby ratings apply to installations served by a reliable utility source. The standby rating is applicable to varying loads for the duration of a power outage. There is no overload capability for this rating. Ratings are in accordance with ISO-3046/1, BS 5514, AS 2789, and DIN 6271.

PRIME POWER RATINGS: Prime power ratings apply to installations where utility power is unavailable or unreliable. At varying load the number of generator set operating hours is unlimited. A 10% overload capacity is available for one hour in twelve. Ratings in accordance with ISO-8528/1, overload power in accordance with ISO-3046/1, BS5514, AS2789, and DIN 6271. For limited running time and base load ratings consult the factory. The generator set manufacturer reserves the right to change the design or specifications without notice and without any obligation or liability whatsoever.

GENERAL GUIDELINES FOR DERATION: Altitude: Derate 0.5% per 100m (328 ft.) elevation above 1000m (3279 ft.)

Temperature: Derate 1.0% per 10°C (18°F) temperature above 40°C (104°F).

APPLICATION & ENGINEERING DATA

ENGINE

Engine Specifications	60 Hz	50 Hz
Manufacturer	Perkins	
Engine, model, type	1104A-44TG1 DIRECT INJECTION TURBOCHARGED	
Cylinder arrangement	4 Vertical in-line	
Displacement, cu. in. (L)	269 (4.4)	
Bore and stroke, in. (mm)	4.13 (105) x 5 (127)	
Compression ratio	17.25:1	
Piston speed, ft/sec. (m/sec)	25 (7.62)	20.8 (6.35)
Rated rpm	1800	1500
Max. power at rated rpm, hp (kw)	104.3 (77.8)	87.9 (65.6)
Firing Order	1,3,4,2	
Governor type	Mechanical	
Speed Variation at Constant Load	± 0.5%	
Combustion air, ft ³ /min. (m ³ /min.)	194.2 (5.5)	148.3 (4.2)
Max. Air Intake Restriction Dirty Filter kPa	8	
Air cleaner type, all models	DRY PAPER ELEMENT	

EXHAUST

Exhaust System	60 Hz	50 Hz
Exh. flow at rated kW, ft ³ /min. (m ³ /min.)	504.9 (14.3)	402.5 (11.4)
Exhaust temperature at rated kW, dry exhaust, °F (°C)	995 (535)	1022 (550)
Maximum allowable back pressure, in. Hg (kPa)	4.4" HG (15 KPA)	
Exhaust outlet size at hookup, in. (mm)	2.5" (63.9)	

ENGINE ELECTRICAL

Engine Electrical System	60 Hz	50 Hz
Battery charging alternator:		
Ground (negative/positive).....	Negative	
Volts (DC).....	12	
Ampere rating.....	65	
Starter motor rated voltage (DC)	12	
Recommended battery cold cranking amps (CCA) rating for 0°F (-18°C)	900	
Quantity of batteries	1	
Battery voltage (DC)	12	

CONTROL PANEL

DGC-500 Digital Genset Controller utilizes microprocessor based technology to provide a versatile system for genset control, protection and monitoring. This microprocessor design allows customization of the controller's functions to fit virtually every application's needs. DGC-500 accepts conventional engine sender inputs. These can be customized via the BESTCOMS PC software to allow virtually any sender to be used.

TOTAL MONITORED PARAMETERS

● GENERATOR

- Voltage (A & B phases and A & B phases to neutral)
- Current (A & B phases)
- kVA total and per phase
- Frequency

● ENGINE

- Oil pressure
- Coolant temperature
- Fuel Level
- Battery voltage
- Hours to next service
- Total run time
- Engine RPM

● TIMERS

- Eng. cooldown: 0 to 60 minutes
- Eng. maint.: 0 to 5000 hours
- Pre-Alarm time delays:
 - Weak batt. & low batt. volt: 1-10 seconds
- Alarm time delays:
 - Overspeed: 0-500ms
 - Sender failure: 0-10 seconds
- Arming delays after crank disconnect:
 - Low oil pressure: 5-15 seconds
 - High coolant temp.: 50-150 seconds
- Pre-crank delay: 0-30 seconds

FUEL

Fuel System	60 Hz	50 Hz
Fuel Injection Pump	Rotary	
Type of Injection	Direct	
Elect. Fuel Pump Pressure	4.4-10.9 psi	
Fuel Lift Pump Flow/Hour	120-150 l/hr (31.7-39.6 gal./hr.)	
Maximum Suction Head	2.9 psi	
Fuel filter	ENVIRONMENTAL ECO PLUS	
Recommended fuel	#2 diesel	

FUEL CONSUMPTION

Fuel Consumption	60 Hz	50 Hz
Diesel, gph (Lph) at % of load		
110%	5.2 (19.7)	4.3 (16.5)
100%	4.7 (17.8)	3.9 (14.8)
75%	3.6 (13.5)	2.9 (11.2)
50%	2.6 (9.7)	2.1 (8.0)

COOLING

Cooling System	60 Hz	50 Hz
Max. Ambient Oper. temp. °F (°C)	127 (53)	
Radiator system capacity, including engine, gal. (L)	3.43 (13)	
Engine jacket water flow, gpm (Lpm)	44.9 (170)	37.5 (142)
Max. Top Tank Temperature °F (°C)	230 (110)	
Water pump type	centrifugal	
Fan Diameter in (mm)	18 (457)	
Cooling Fan Air Flow ft ³ /min. (m ³ /min.)	3919 (111)	3143 (89)
Heat to Radiation kW (Btu/min)	13 (740)	12 (683)

LUBRICATION

Lubricating System	60 Hz	50 Hz
Cast Iron Sump with Filler and Dipstick		
Max. Continuous Oil Temperature	257° F	
Oil pan capacity total system, qts. (L)	8.5 (8)	
Oil filter, quantity, type	1 spin on	
Oil Pressure at Max. Rated Speed (no load)	40 to 60 psi	

● GENERATOR SET PROTECTION

ALARMS:

- Low oil pressure
- Overspeed
- Overcrank
- Emerg. Stop button input
- High coolant temp.
- Sender failure
- Low coolant level
- Low fuel level

PRE-ALARMS:

- Low oil pressure
- Low battery voltage
- Maintenance interval timer
- High coolant temp.
- Low coolant temp.
- High battery voltage
- Fuel leak
- Weak battery
- Low fuel level
- Battery charger failure

GENERATOR SPECIFICATIONS

STANDARDS

UC224 and UC274 industrial generators meet the requirements of BS5000, VDE0530, UTE5100, NEMA MG1-22, CEMA, IEC34-1, CSA22.2 AND AS1359.

EXCITATION SYSTEMS

SX440 & SX460 AVR

With these self-excited systems the main stator provides power via the automatic voltage regulator (AVR) to the exciter stator. The high efficiency semiconductors of the (AVR) ensure positive build up from initial low levels of residual voltage.

The exciter rotor output is fed to the main rotor through a three phase full wave bridge rectifier. The rectifier is protected by a surge suppressor against surges caused, for example, by short circuit or out of phase paralleling. The SX440 will support a range of electronic accessories, including a 'droop' Current Transformer (CT) to permit parallel operation with other ac generators.

MX341 AVR

This sophisticated AVR is incorporated into the permanent magnet generator (PMG) system, and is fitted as an option on industrial generators.

The PMG provides power via the AVR to the main exciter, giving a source of constant excitation power independent of generator output. The main exciter output is then fed to the main rotor, through a full wave bridge, protected by a surge suppressor. The AVR has built-in protection against sustained over-excitation, caused by internal or external faults. This de-excites the machine after a minimum of 5 seconds.

The two phase average voltage sensed MX341 provides voltage regulation of $\pm 1.0\%$. If three phase sensing is required with the PMG system the MX321 AVR must be used. We recommend three phase sensing for applications with greatly unbalanced or highly non-linear loads. An engine relief load acceptance feature can enable full load to be applied to the generator in a single step.

MX321 AVR

The most sophisticated of all our AVRs combines all the features of the MX341 with, additionally, three phase rms sensing, for improved regulation (0.5%) and performance. Over voltage protection is built-in and short circuit current level adjustment is an optional facility.

INSULATION / IMPREGNATION

The insulation system is Class 'H'.

All wound components are impregnated with materials and processes designed specifically to provide protection against the harsh environments encountered in generator applications. Varnishes and resins are selected and developed to provide the high build required for static windings and the high mechanical strength required for rotating components.

WINDINGS & ELECTRICAL PERFORMANCE

All generator stators are wound to $2/3$ pitch. This eliminates triplen (3rd, 9th, 15th...) harmonics on the voltage waveform and is found to be the optimum design for trouble-free supply of non linear loads. The $2/3$ pitch design avoids excessive neutral currents, sometimes seen with higher winding pitches, when in parallel with the mains.

A fully connected damper winding reduces oscillations during paralleling. This winding, with $2/3$ pitch and carefully selected pole and tooth designs, ensures very low waveform distortion.

TELEPHONE INTERFERENCE

THF (as defined by BS4999 Part 40) is better than 2%. TIF (as defined by ASA C50.12) is better than 50.

RADIO INTERFERENCE

The absence of brushgear and the high quality AVR ensure low levels of interference with radio transmissions.

Additional RFI suppression may be supplied if required.

ENCLOSURE

IP22 (NEMA 1) is standard for all industrial generators Protection to IP23 (60 degrees from vertical) is available as an option at reduced ratings (5% derate).

Inlet air filters are available as an option on all generators, at reduced ratings (5% derate).

SHAFT

All generator rotors are dynamically balanced to better than BS6861: Part 1 Grade 2.5 for minimum vibration in operation.

QUALITY ASSURANCE

Generators are manufactured using production procedures having a quality assurance level to BS EN (ISO9001).

STANDARD FEATURES AND ACCESSORIES

Standard Features

- Heavy duty steel base
- Vibration isolators
- Oil drain valve with extension
- Flex exhaust connector
- Battery rack
- Battery cables
- Water jacket heater
- Owners manual

Accessories

- Generator strip heater
- Line circuit breaker
- DGC 500 Multifunction Protection
- DGC 1000 controls
- Standard Dial Out Modem
- Extended Temperature Modem
- Enhanced Communication
- Auxiliary Contacts
- Surface Mount Remote Annunciator
- Flush Mount Remote Annunciator

Accessories

- Exhaust silencer
- Silencer mounting kit for enclosure
- Weather enclosure
- Sound attenuated enclosure
- Sub-base fuel tank
- Flexible fuel lines
- Day tank
- Oil pan heater
- Battery
- Battery heater
- Battery charger
- PMG exciter
- Electronic Isochronous Governor

WEIGHTS AND DIMENSIONS

DS65

Overall Size, L x W x H, in.: (81" x 36" x 54")

Weight (wet): 1950 Lbs.

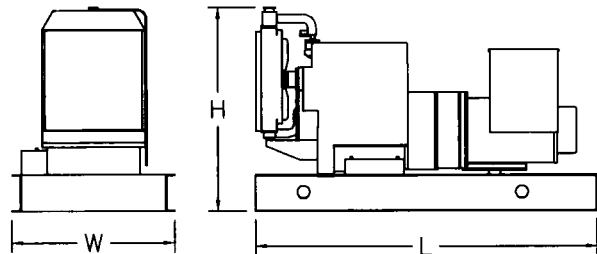

Note: This drawing is provided for reference only and should not be used for planning installation. Contact your local distributor for more detailed information.

TAYLOR POWER SYSTEMS

461 Hwy. 49S
Richland, Mississippi 39218
Phone (601)-932-5674
Toll Free 1-800-367-7639
FAX (601)-932-4028
Web Site www.taylorpower.com

DISTRIBUTED BY: