

# TAYLOR<sup>®</sup>

## POWER SYSTEMS

**Model: DS45M2**

**Ratings Range:**

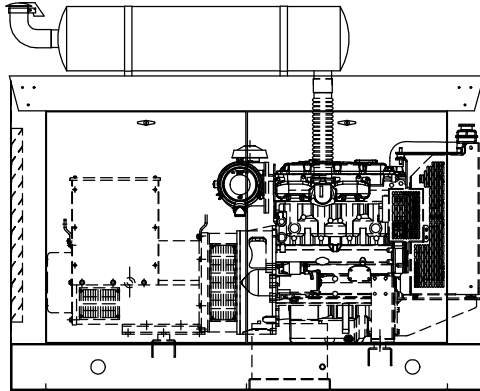

DRAWING DEPICTS UNIT WITH OPTIONAL EQUIPMENT

### Features

- **Single source responsibility for the generator set and accessories.**
- **Prototype and production tested to insure one step load acceptance per NFPA 110.**
- **Two year limited warranty on generator sets and accessories.**
- **Unit conforms to CSA, NEMA, EGSA, ANSI and other standards.**
- **Microprocessor based control system providing digital metering and monitoring.**
- **Heavy duty 4 cycle industrial engine for reliability and fuel efficiency.**
- **Brushless rotating field generator with class H insulation.**
- **Heavy duty steel base with integral vibration isolators.**

		50Hz	60Hz
<b>Standby:</b>	<b>kw</b>	<b>32 - 40</b>	<b>33.5 - 46.5</b>
	<b>kva</b>	<b>40 - 50</b>	<b>45 - 58</b>
<b>Prime:</b>	<b>kw</b>	<b>28.8 - 36</b>	<b>32.8 - 42</b>
	<b>kva</b>	<b>36 - 45</b>	<b>41 - 52.5</b>

Generator	Voltage	PH	Hz	125°C Rise		105°C Rise	
				Standby kW/kVA	Amps	Prime kW/kVA	Amps
UCI224C311	277/480	3	60	44/55	66	38.4/48	59
	139/240	3	60	44/55	132	38.4/48	115
	254/440	3	60	42/52.5	69	37/46	61
	127/220	3	60	42/52.5	138	37/46	121
	240/416	3	60	40/50	69	36/46	64
	120/208	3	60	40/50	139	36/46	128
	120/240	3	60	40/50	120	36/46	111
	219/380	3	60	36/45	69	32.8/41	62
	120/240	1	60	33.5/33.5	140	30/30	125
	254/440	3	50	32/40	52	28.8/36	47
	127/220	3	50	32/40	105	28.8/36	94
	120/208	3	50	34/42.5	118	30/37.5	104
	240/415	3	50	34/42.5	59	30/37.5	52
	219/380	3	50	34/42.5	65	30/37.5	57
	110/190	3	50	34/42.5	129	30/37.5	114
	110/220	1	50	28.5/28.5	130	25/25	104
UCI224D311	277/480	3	60	46.5/58	70	42/52.5	63
	139/240	3	60	46.5/58	140	42/52.5	126
	254/440	3	60	46.5/58	76	42/52.5	69
	127/220	3	60	46.5/58	152	42/52.5	138
	240/416	3	60	46.5/58	81	42/52.5	73
	120/208	3	60	46.5/58	161	42/52.5	145
	120/240	3	60	46.5/58	140	42/52.5	126
	219/380	3	60	44/55	83	38/48	73
	120/240	1	60	40/40	167	35/35	146
	254/440	3	50	38/47.5	62	34/43	56
	127/220	3	50	38/47.5	125	34/43	113
	120/208	3	50	40/50	139	36/45	125
	240/415	3	50	40/50	70	36/45	63
	219/380	3	50	40/50	76	36/45	68
	110/190	3	50	40/50	110	36/45	137
	110/220	1	50	33.5/33.5	152	30/30	136
UCI224C06	120/240	1	60	37.5/37.5	156	33.8/33.8	141
UCI224D06	120/240	1	60	44/44	183	40/40	167
UCI224E06	120/240	1	60	46.5/46.5	194	42/42	175

RATINGS: All three-phase units are rated at 0.8 power factor. All single-phase units are rated at 1.0 power factor.

STANDBY RATINGS: Standby ratings apply to installations served by a reliable utility source. The standby rating is applicable to varying loads for the duration of a power outage. There is no overload capability for this rating. Ratings are in accordance with ISO-3046/1, BS 5514, AS 2789, and DIN 6271.

PRIME POWER RATINGS: Prime power ratings apply to installations where utility power is unavailable or unreliable. At varying load the number of generator set operating hours is unlimited. A 10% overload capacity is available for one hour in twelve. Ratings are in accordance with ISO-8528/1, overload power in accordance with ISO-3046/1, BS5514, AS2789, and DIN 6271. For limited running time and base load ratings consult the factory. The generator set manufacturer reserves the right to change the design or specifications without notice and without any obligation or liability whatsoever.

GENERAL GUIDELINES FOR DERATION: Altitude: Derate 0.5% per 100m (328 ft.) elevation above 1000m (3279 ft.)

Temperature: Derate 1.0% per 10°C (18°F) temperature above 40°C (104°F).

# APPLICATION & ENGINEERING DATA

## ENGINE

Engine Specifications	60 Hz	50 Hz
Manufacturer	Perkins	
Engine, model, type	1104C-44G2 DIRECT INJECTION Naturally Aspirated	
Cylinder arrangement	4 Vertical in-line	
Displacement, cu. in. (L)	269 (4.4)	
Bore and stroke, in. (mm)	4.13 (105) x 5 (127)	
Compression ratio	19.3:1	
Piston speed, ft/sec. (m/sec)	25 (7.62)	20.8 (6.35)
Rated rpm	1800	1500
Max. power at rated rpm, hp (kw)	72.6 (54.2)	58.2 (43.5)
Firing Order	1,3,4,2	
Governor type	Mechanical	
Speed Variation at Constant Load	± 0.5%	
Combustion air, ft <sup>3</sup> /min. (m <sup>3</sup> /min.)	125 (3.55)	100 (2.84)
Max. Air Intake Restriction Dirty Filter kPa	6.6	
Air cleaner type, all models	2 STAGE CYCLONIC PAPER ELEMENT	

## EXHAUST

Exhaust System	60 Hz	50 Hz
Exh. flow at rated kW, ft <sup>3</sup> /min. (m <sup>3</sup> /min.)	351 (9.95)	269 (7.63)
Exhaust temperature at rated kW, dry exhaust, °F (°C)	1257 (676)	1108 (598)
Maximum allowable back pressure, in. Hg (kPa)	4.4" HG (15 KPA)	
Exhaust outlet size at hookup, in. (mm)	2.5" (63.9)	

## ENGINE ELECTRICAL

Engine Electrical System	60 Hz	50 Hz
Battery charging alternator: Ground (negative/positive)..... Volts (DC)..... Ampere rating.....	Negative 12 65	
Starter motor rated voltage (DC)	12	
Recommended battery cold cranking amps (CCA) rating for 0 °F (-18 °C)	770	
Quantity of batteries	1	
Battery voltage (DC)	12	

## CONTROL PANEL

The DGC-2020 Digital Genset Controller provides integrated engine-genset control, protection, and metering in a single package. Microprocessor based technology allows for exact measurement, setpoint adjustment, and timing functions. Front panel controls and indicators enable quick and simple DGC-2020 operation. A wide temperature-range liquid crystal display (LCD) with backlighting can be viewed under a wide range of ambient light and temperature conditions.

### Features

- Generator Metering
- Engine Metering
- Genset Control
- Engine Protection
- Generator Protection (27, 59, 810, 81U)
- SAE J1939 Engine ECU communications
- Multilingual capability
- Remote RS-485 communications for Optional RDP-110 Remote Annunciator
- Extremely rugged, fully encapsulated design
- 16 programmable contact inputs

- 7 contact outputs: (3) 30 Adc contacts (4) programmable 2 Adc rated contacts
- Wide Ambient Temperature Range
- Modbus Communications with RS-485
- Battery Backup for Real Time Clock
- LCD Heater allows for use of DGC-2020 in temp. down to -40°C
- UL recognized, CSA certified, CE approved
- HALT (Highly Accelerated Life Tests) tested
- IP 54 Front Panel rating with integrated gasket
- NFPA 110 Level Compatible

### Options

- Additional (8) Programmable 2 Adc contacts
- Remote Dial-out and Dial-in capability with Internal Modem
- Enhanced Generator Protection 51 and 47

## FUEL

Fuel System	60 Hz	50 Hz
Fuel Injection Pump	Rotary	
Fuel Lift Pump Flow	5/16 (7.93)	
Fuel return line, min. ID, in. (mm)	1/4 (6.35)	
Type of Injection	Direct	
Fuel Lift Pump FLOW/Hour	120-150 l/hr (31.7-39.6 gal./hr.)	
Fuel filter	ENVIRONMENTAL ECO PLUS	
Recommended fuel	#2 diesel	

## FUEL CONSUMPTION

Fuel Consumption	60 Hz	50 Hz
<b>Diesel, gph (Lph) at % of load</b>		
110%	3.5 (13.4)	3.1 (11.7)
100%	3.2 (12.1)	2.8 (10.6)
75%	2.4 (9.2)	2 (7.8)
50%	1.72 (6.5)	1.4 (5.4)

## COOLING

Cooling System	60 Hz	50 Hz
Max. Ambient Oper. temp. °F (°C)	127 (53)	
Radiator system capacity, including engine, gal. (L)	3.38 (12.8)	
Engine jacket water flow, gpm (Lpm)	44.9 (170)	37.5 (142)
Max. Top Tank Temperature °F (°C)	230 (110)	
Water pump type	centrifugal	
Fan Diameter in (mm)	18 (457)	
Cooling Fan Air Flow ft <sup>3</sup> /min. (m <sup>3</sup> /min.)	2882 (81.6)	2055 (58.2)
Heat to Radiation kW (Btu/min)	8 (455)	7 (398)

## LUBRICATION

Lubricating System	60 Hz	50 Hz
Cast Iron Sump with Filler and Dipstick		
Normal Oil Temperature	230° F	
Oil pan capacity with filter, qts. (L)	7.4 (7)	
Oil filter, quantity, type	1 spin on	
Oil Pressure at Rated Speed	Minimum 36 psi	

# GENERATOR SPECIFICATIONS

---

## STANDARDS

UC224 and UC274 industrial generators meet the requirements of BS5000, VDE0530, UTE5100, NEMA MG1-22, CEMA, IEC34-1, CSA22.2 AND AS1359.

## EXCITATION SYSTEMS

### **SX440 & SX460 AVRs**

With these self-excited systems the main stator provides power via the automatic voltage regulator (AVR) to the exciter stator. The high efficiency semiconductors of the (AVR) ensure positive build up from initial low levels of residual voltage.

The exciter rotor output is fed to the main rotor through a three phase full wave bridge rectifier. The rectifier is protected by a surge suppressor against surges caused, for example, by short circuit or out of phase paralleling. The SX440 will support a range of electronic accessories, including a 'droop' Current Transformer (CT) to permit parallel operation with other ac generators.

### **MX341 AVR**

This sophisticated AVR is incorporated into the permanent magnet generator (PMG) system, and is fitted as an option on industrial generators.

The PMG provides power via the AVR to the main exciter, giving a source of constant excitation power independent of generator output. The main exciter output is then fed to the main rotor, through a full wave bridge, protected by a surge suppressor. The AVR has built-in protection against sustained over-excitation, caused by internal or external faults. This de-excites the machine after a minimum of 5 seconds.

The two phase average voltage sensed MX341 provides voltage regulation of  $\pm 1.0\%$ . If three phase sensing is required with the PMG system the MX321 AVR must be used. We recommend three phase sensing for applications with greatly unbalanced or highly non-linear loads. An engine relief load acceptance feature can enable full load to be applied to the generator in a single step.

### **MX321 AVR**

The most sophisticated of all our AVRs combines all the features of the MX341 with, additionally, three phase rms sensing, for improved regulation ( $\pm 0.5\%$ ) and performance. Over voltage protection is built-in and short circuit current level adjustment is an optional facility.

## INSULATION / IMPREGNATION

The insulation system is Class 'H'.

All wound components are impregnated with materials and processes designed specifically to provide protection against the harsh environments encountered in generator applications. Varnishes and resins are selected and developed to provide the high build required for static windings and the high mechanical strength required for rotating components.

## WINDINGS & ELECTRICAL PERFORMANCE

All generator stators are wound to 2/3 pitch. This eliminates triplen (3rd, 9th, 15th...) harmonics on the voltage waveform and is found to be the optimum design for trouble-free supply of non linear loads. The 2/3 pitch design avoids excessive neutral currents, sometimes seen with higher winding pitches, when in parallel with the mains.

A fully connected damper winding reduces oscillations during paralleling. This winding, with 2/3 pitch and carefully selected pole and tooth designs, ensures very low waveform distortion.

## TELEPHONE INTERFERENCE

THF (as defined by BS4999 Part 40) is better than 2%. TIF (as defined by ASA C50.12) is better than 50.

## RADIO INTERFERENCE

The absence of brushgear and the high quality AVR ensure low levels of interference with radio transmissions.

Additional RFI suppression may be supplied if required.

## ENCLOSURE

IP22 (NEMA 1) is standard for all industrial generators Protection to IP23 (60 degrees from vertical) is available as an option at reduced ratings (5% derate).

Inlet air filters are available as an option on all generators, at reduced ratings (5% derate).

## SHAFT

All generator rotors are dynamically balanced to better than BS6861: Part 1 Grade 2.5 for minimum vibration in operation.

## QUALITY ASSURANCE

Generators are manufactured using production procedures having a quality assurance level to BS EN (ISO9001).

# STANDARD FEATURES AND ACCESSORIES

## Standard Features

- Heavy duty steel base
- Vibration isolators
- Oil drain valve with extension
- Flex exhaust connector
- Battery rack
- Battery cables
- Water jacket heater
- Owners manual

## Accessories

- Generator strip heater
- Line circuit breaker
- DGC-2020 Enhanced generator protection
- DGC-2020 Internal Modem
- DGC-2020 Programmable Aux. Contacts qty. (8) 2Adc
- Surface Mount Remote Annunciator
- Flush Mount Remote Annunciator
- Analog Auto-Start Control Panel

## Accessories

- Exhaust silencer
- Silencer mounting kit for enclosure
- Weather enclosure
- Sound attenuated enclosure
- Sub-base fuel tank
- Flexible fuel lines
- Day tank
- Oil pan heater
- Battery
- Battery heater
- Battery charger
- PMG exciter
- Electronic Isochronous Governor

## WEIGHTS AND DIMENSIONS

### DS45M2

Overall Size, L x W x H, in.: (81" x 36" x 54")

Weight (wet): 1800 Lbs.

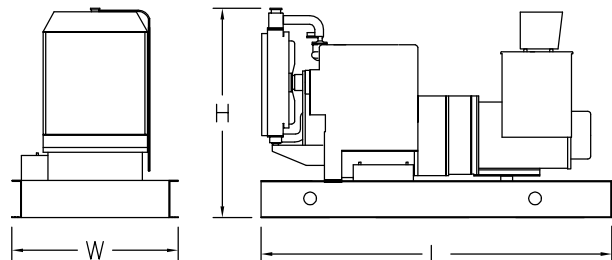

Note: This drawing is provided for reference only and should not be used for planning installation. Contact your local distributor for more detailed information.

# TAYLOR POWER SYSTEMS

461 Hwy. 49S

Richland, Mississippi 39218

Phone (601)-932-5674

Toll Free 1-800-367-7639

FAX (601)-932-4028

Web Site [www.taylorpower.com](http://www.taylorpower.com)

## DISTRIBUTED BY: