

TAYLOR[®]

POWER SYSTEMS

Model: **DS200M2**

Ratings Range:

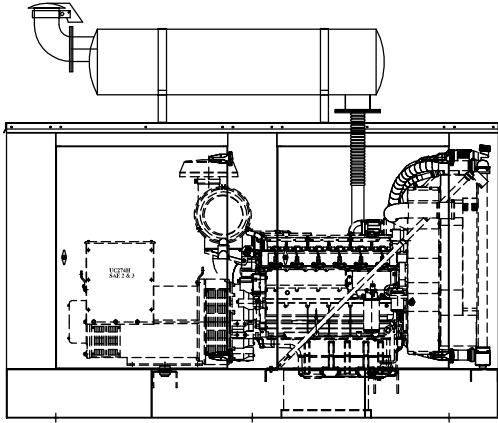

DRAWING DEPICTS UNIT WITH OPTIONAL EQUIPMENT

Features

- **Single source responsibility for the generator set and accessories.**
- **Prototype and production tested to insure one step load acceptance per NFPA 110.**
- **Two year limited warranty on generator sets and accessories.**
- **Unit conforms to CSA, NEMA, EGSA, ANSI and other standards.**
- **Microprocessor based control system providing digital metering and monitoring.**
- **Heavy duty 4 cycle industrial engine for reliability and fuel efficiency.**
- **Brushless rotating field generator with class H insulation.**
- **Heavy duty steel base with integral vibration isolators.**
- **Electronic Isochronous Governor**
- **EPA Tier 2 Certified Engine**

		50Hz	60Hz
Standby:	kw	152 - 160	170 - 200
	kva	190 - 200	213 - 250
Prime:	kw	138 - 151	160 - 180
	kva	172 - 189	200 - 225

Generator	Voltage	PH	Hz	125°C Rise		105°C Rise	
				Standby	Rating	Prime	Rating
				kW/kVA	Amps	kW/kVA	Amps
UCI274H311	277/480	3	60	200/250	301	180/225	271
	139/240	3	60	200/250	602	180/225	542
	254/440	3	60	196/245	321	180/225	295
	127/220	3	60	196/245	643	180/225	590
	240/416	3	60	190/238	330	175/219	304
	120/208	3	60	190/238	661	175/219	608
	120/240	3	60	190/238	573	175/219	527
	219/380	3	60	170/213	324	160/200	304
	120/240	1	60	143/143	596	131/131	546
	254/440	3	50	152/190	249	138/172	226
	127/220	3	50	152/190	499	138/172	451
	120/208	3	50	160/200	555	146/182	505
	240/415	3	50	160/200	278	146/182	253
	219/380	3	50	160/200	304	146/182	277
	110/190	3	50	160/200	608	146/182	553
	110/220	1	50	120/120	545	110/110	500
UCD274J311	277/480	3	60	200/250	301	180/225	271
	139/240	3	60	200/250	602	180/225	542
	254/440	3	60	200/250	328	180/225	296
	127/220	3	60	200/250	657	180/225	591
	240/416	3	60	200/250	347	180/225	313
	120/208	3	60	200/250	695	180/225	625
	120/240	3	60	200/250	602	180/225	542
	219/380	3	60	200/250	380	180/225	219
	120/240	1	60	160/160	667	150/150	625
	254/440	3	50	160/200	263	148/185	243
	127/220	3	50	160/200	525	148/185	486
	120/208	3	50	160/200	556	151/189	525
	240/415	3	50	160/200	279	151/189	263
	219/380	3	50	160/200	304	151/189	287
	110/190	3	50	160/200	608	151/189	574
	110/220	1	50	138/138	627	127/127	577
HCI444E06	120/240	1	60	200/200	833	160/160	667

RATINGS: All three-phase units are rated at 0.8 power factor. All single-phase units are rated at 1.0 power factor.

STANDBY RATINGS: Standby ratings apply to installations served by a reliable utility source. The standby rating is applicable to varying loads for the duration of a power outage. There is no overload capability for this rating. Ratings are in accordance with ISO-3046/1, BS 5514, AS 2789, and DIN 6271.

PRIME POWER RATINGS: Prime power ratings apply to installations where utility power is unavailable or unreliable. At varying load the number of generator set operating hours is unlimited. A 10% overload capacity is available for one hour in twelve. Ratings are in accordance with ISO-8528/1, overload power in accordance with ISO-3046/1, BS5514, AS2789, and DIN 6271. For limited running time and base load ratings consult the factory. The generator set manufacturer reserves the right to change the design or specifications without notice and without any obligation or liability whatsoever.

GENERAL GUIDELINES FOR DERATION: Altitude: Derate 0.5% per 100m (328 ft.) elevation above 1000m (3279 ft.)

Temperature: Derate 1.0% per 10°C (18°F) temperature above 40°C (104°F).

APPLICATION & ENGINEERING DATA

ENGINE

Engine Specifications	60 Hz	50 Hz
Manufacturer	VOLVO	
Engine, model, type	TAD722GE 4-CYCLE Tier 2 Air to air intercooled	
Cylinder arrangement	6 vertical, in-line	
Displacement, cu. in. (L)	436.3 (7.15)	
Bore and stroke, in. (mm)	4.25 (108) x 5.12 (130)	
Compression ratio	18.1:1	
Piston speed, ft./sec. (m/sec)	25.7 (7.8)	21.4 (6.5)
Rated rpm	1800	1500
Max. power at rated rpm, hp (kw)	296 (218)	268 (197)
Cylinder head material	Cast iron	
Crankshaft material	Forged steel	
Governor type	Heinzmann / EDC 4	
Air cleaner type, all models	Dry paper element w/air rest. indicator	
Injection Pump Type	Single Bosch w/ EDC4 actuator	

EXHAUST

Exhaust System	60 Hz	50 Hz
Exhaust flow at rated kW, cfm (m ³ /min.)	1607 (45.5)	1314 (37.2)
Exhaust temperature at rated kW, dry exhaust, °F (°C)	968 (520)	1035 (557)
Maximum allowable back pressure, in. wc (kPa)	28.1 (7 KPA)	20.1 (5 KPA)
Heat Rejected to Exhaust: BTU/min	10123	9099

ENGINE ELECTRICAL

Engine Electrical System	60 Hz	50 Hz
Battery charging alternator: Ground (negative/positive).....	Negative	
Volts (DC).....	24	
Ampere rating.....	55	
Starter motor rated voltage (DC)	24	
Recommended battery cold cranking amps (CCA) rating for +20° C	400	
Quantity of batteries	2	
Battery voltage (DC)	24	

CONTROL PANEL

The DGC-2020 Digital Genset Controller provides integrated engine-genset control, protection, and metering in a single package. Microprocessor based technology allows for exact measurement, setpoint adjustment, and timing functions. Front panel controls and indicators enable quick and simple DGC-2020 operation. A wide temperature-range liquid crystal display (LCD) with backlighting can be viewed under a wide range of ambient light and temperature conditions.

Features

- Generator Metering
- Engine Metering
- Genset Control
- Engine Protection
- Generator Protection (27, 59, 810, 81U)
- SAE J1939 Engine ECU communications
- Multilingual capability
- Remote RS-485 communications for Optional RDP-110 Remote Annunciator
- Extremely rugged, fully encapsulated design
- 16 programmable contact inputs
- 7 contact outputs: (3) 30 Adc contacts (4) programmable 2 Adc rated contacts
- Wide Ambient Temperature Range
- Modbus Communications with RS-485
- Battery Backup for Real Time Clock
- LCD Heater allows for use of DGC-2020 in temp. down to -40°C
- UL recognized, CSA certified, CE approved
- HALT (Highly Accelerated Life Tests) tested
- IP 54 Front Panel rating with integrated gasket
- NFPA 110 Level Compatible

Options

- Additional (8) Programmable 2 Adc contacts
- Remote Dial-out and Dial-in capability with Internal Modem
- Enhanced Generator Protection 51 and 47

FUEL

Fuel System	60 Hz	50 Hz
Total Fuel Flow U.S. gal./hour	119	95
Feed Pump Pressure psi (kPa)	72.5 (500)	
Feed Pump Max. Suction Head ft. (m)	4.9 (1.5)	
Injection Timing std.	4° B.T.D.C.	
Fuel filters	1 Spin on Type and 1 Fuel Pre-Filter W/ water separator	
Recommended fuel	#2 diesel	

FUEL CONSUMPTION

Fuel Consumption	60 Hz	50 Hz
Diesel, gph (Lph) at % of load		
100%	14 (53)	12.9 (49)
75%	12.4 (47)	12.2 (46)
50%	6.6 (25)	6.6 (25)

COOLING

Cooling System	60 Hz	50 Hz
Coolant Capacity U.S. gal. (liters) radiator with hoses	7.21 (27.3)	
Coolant Flow U.S. gal/s (liter/s)	.95 (3.6)	.79 (3)
Fan Power Consumption hp (kw)	10 (7.4)	6 (4.4)
Fan Diameter in. (mm)	30.31 (770)	
Heat rejected to cooling water at rated kW, dry exhaust Btu/min.	5835	5147
Water pump type	Belt Driven Efficient Cooling Pump	
Air Consumption at Rated rpm cfm (m ³ /min.)	562 (15.9)	449 (12.7)

LUBRICATION

Lubricating System	60 Hz	50 Hz
Type	FULL PRESSURE W/ INTEGRATED FULL FLOW OIL COOLER	
Oil pan capacity with filter, U.S. GAL (L)	8.9 (34)	
Oil filter, quantity, type	1 FULL FLOW DISPOSABLE	
Oil cooler	full flow oil cooler	
Oil Pressure at Rated Speed psi	64	58

GENERATOR SPECIFICATIONS

STANDARDS

UC224 and UC274 industrial generators meet the requirements of BS5000, VDE0530, UTE5100, NEMA MG1-22, CEMA, IEC34-1, CSA22.2 AND AS1359.

EXCITATION SYSTEMS

SX440 & SX460 AVRs

With these self-excited systems the main stator provides power via the automatic voltage regulator (AVR) to the exciter stator. The high efficiency semiconductors of the (AVR) ensure positive build up from initial low levels of residual voltage.

The exciter rotor output is fed to the main rotor through a three phase full wave bridge rectifier. The rectifier is protected by a surge suppressor against surges caused, for example, by short circuit or out of phase paralleling. The SX440 will support a range of electronic accessories, including a 'droop' Current Transformer (CT) to permit parallel operation with other ac generators.

MX341 AVR

This sophisticated AVR is incorporated into the permanent magnet generator (PMG) system, and is fitted as an option on industrial generators.

The PMG provides power via the AVR to the main exciter, giving a source of constant excitation power independent of generator output. The main exciter output is then fed to the main rotor, through a full wave bridge, protected by a surge suppressor. The AVR has built-in protection against sustained over-excitation, caused by internal or external faults. This de-excites the machine after a minimum of 5 seconds.

The two phase average voltage sensed MX341 provides voltage regulation of $\pm 1.0\%$. If three phase sensing is required with the PMG system the MX321 AVR must be used. We recommend three phase sensing for applications with greatly unbalanced or highly non-linear loads. An engine relief load acceptance feature can enable full load to be applied to the generator in a single step.

MX321 AVR

The most sophisticated of all our AVRs combines all the features of the MX341 with, additionally, three phase rms sensing, for improved regulation ($\pm 0.5\%$) and performance. Over voltage protection is built-in and short circuit current level adjustment is an optional facility.

INSULATION / IMPREGNATION

The insulation system is Class 'H'.

All wound components are impregnated with materials and processes designed specifically to provide protection against the harsh environments encountered in generator applications. Varnishes and resins are selected and developed to provide the high build required for static windings and the high mechanical strength required for rotating components.

WINDINGS & ELECTRICAL PERFORMANCE

All generator stators are wound to 2/3 pitch. This eliminates triplen (3rd, 9th, 15th...) harmonics on the voltage waveform and is found to be the optimum design for trouble-free supply of non linear loads. The 2/3 pitch design avoids excessive neutral currents, sometimes seen with higher winding pitches, when in parallel with the mains.

A fully connected damper winding reduces oscillations during paralleling. This winding, with 2/3 pitch and carefully selected pole and tooth designs, ensures very low waveform distortion.

TELEPHONE INTERFERENCE

THF (as defined by BS4999 Part 40) is better than 2%. TIF (as defined by ASA C50.12) is better than 50.

RADIO INTERFERENCE

The absence of brushgear and the high quality AVR ensure low levels of interference with radio transmissions.

Additional RFI suppression may be supplied if required.

ENCLOSURE

IP22 (NEMA 1) is standard for all industrial generators Protection to IP23 (60 degrees from vertical) is available as an option at reduced ratings (5% derate).

Inlet air filters are available as an option on all generators, at reduced ratings (5% derate).

SHAFT

All generator rotors are dynamically balanced to better than BS6861: Part 1 Grade 2.5 for minimum vibration in operation.

QUALITY ASSURANCE

Generators are manufactured using production procedures having a quality assurance level to BS EN (ISO9001).

STANDARD FEATURES AND ACCESSORIES

Standard Features

- Heavy duty steel base
- Vibration isolators
- Oil drain valve with extension
- Flex exhaust connector
- Battery rack
- Battery cables
- Water jacket heater
- Owners manual
- Electronic Isochronous Governor

Accessories

- Generator strip heater
- Line circuit breaker
- DGC-2020 Enhanced generator protection
- DGC-2020 Internal Modem
- DGC-2020 Programmable Aux. Contacts qty. (8) 2Adc
- Surface Mount Remote Annunciator
- Flush Mount Remote Annunciator
- Analog Auto-Start Control Panel

Accessories

- Exhaust silencer
- Silencer mounting kit for enclosure
- Weather enclosure
- Sound attenuated enclosure
- Sub-base fuel tank
- Flexible fuel lines
- Day tank
- Oil pan heater
- Battery
- Battery heater
- Battery charger
- PMG exciter

WEIGHTS AND DIMENSIONS

DS200M2

Overall Size, L x W x H, in.: (120" x 50" x 72")

Weight (wet): 4300 Lbs.

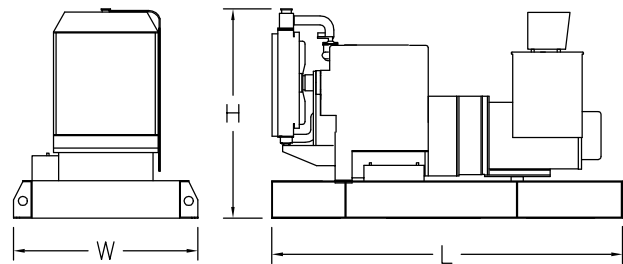

Note: This drawing is provided for reference only and should not be used for planning installation. Contact your local distributor for more detailed information.

TAYLOR

POWER SYSTEMS

461 Hwy. 49S

Richland, Mississippi 39218

Phone (601)-932-5674

Toll Free 1-800-367-7639

FAX (601)-932-4028

Web Site www.taylorpower.com

DISTRIBUTED BY: