

TAYLOR[®]

POWER SYSTEMS

Model: **DS1600M**

Ratings Range:

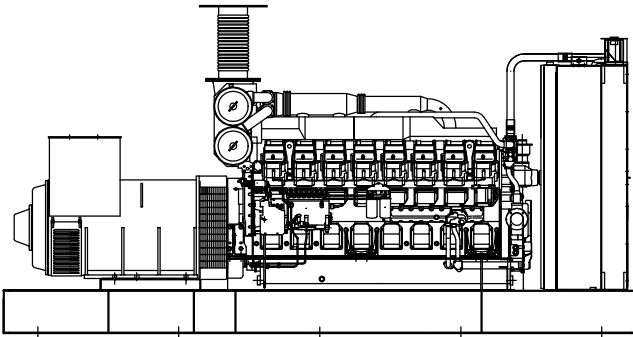

Features

- **Single source responsibility for the generator set and accessories.**
- **Prototype and production tested to insure one step load acceptance per NFPA 110.**
- **Two year limited warranty on generator sets and accessories.**
- **Unit conforms to CSA, NEMA, EGSA, ANSI and other standards.**
- **Microprocessor based control system providing digital metering and monitoring.**
- **Heavy duty 4 cycle industrial engine for reliability and fuel efficiency.**
- **Brushless rotating field generator with class H insulation.**
- **Heavy duty steel base with integral vibration isolators.**
- **Electronic Isochronous Governor**

		50Hz	60Hz
Standby:	kw	1280 - 1168	1230 - 1600
	kva	1460 - 1600	1538 - 2000
Prime:	kw	1064 - 1152	1140 - 1440
	kva	1330 - 1440	1425 - 1800

Generator	Voltage	PH	Hz	125°C Rise		105°C Rise	
				Standby	Rating	Prime	Rating
				kW/kVA	Amps	kW/kVA	Amps
HCI734F	277/480	3	60	1500/1875	2255	1350/1688	2030
	139/240	3	60	1500/1875	4511	1350/1688	4061
	254/440	3	60	1420/1775	2329	1300/1625	2132
	127/220	3	60	1420/1775	4658	1300/1625	4265
	240/416	3	60	1350/1688	2343	1250/1563	2169
	120/208	3	60	1350/1688	4686	1250/1563	4339
	120/240	3	60	1350/1688	4061	1250/1563	3760
	219/380	3	60	1230/1538	2337	1140/1425	2165
	254/440	3	50	1168/1460	1916	1064/1330	1745
	127/220	3	50	1168/1460	3832	1064/1330	3490
	120/208	3	50	1168/1460	4053	1064/1330	3692
	240/415	3	50	1168/1460	2031	1064/1330	1850
	219/380	3	50	1168/1460	2218	1064/1330	2021
	110/190	3	50	1168/1460	4437	1064/1330	4042
	HCI734G	277/480	3	60	1600/2000	2406	1440/1800
139/240		3	60	1600/2000	4811	1440/1800	4330
254/440		3	60	1600/2000	2624	1440/1800	2462
127/220		3	60	1600/2000	5249	1440/1800	4724
240/416		3	60	1600/2000	2776	1440/1800	2498
120/208		3	60	1600/2000	5552	1440/1800	4996
120/240		3	60	1600/2000	2411	1440/1800	4330
219/380		3	60	1500/1875	2849	1380/1725	2621
254/440		3	50	1280/1600	2100	1152/1440	1890
127/220		3	50	1280/1600	4199	1152/1440	3779
120/208		3	50	1280/1600	4441	1152/1440	3997
240/415		3	50	1280/1600	2226	1152/1440	2003
219/380		3	50	1280/1600	2431	1152/1440	2188
110/190		3	50	1280/1600	4862	1152/1440	4376

RATINGS: All three-phase units are rated at 0.8 power factor. All single-phase units are rated at 1.0 power factor.

STANDBY RATINGS: Standby ratings apply to installations served by a reliable utility source. The standby rating is applicable to varying loads for the duration of a power outage. There is no overload capability for this rating. Ratings are in accordance with ISO-3046/1, BS 5514, AS 2789, and DIN 6271.

PRIME POWER RATINGS: Prime power ratings apply to installations where utility power is unavailable or unreliable. At varying load the number of generator set operating hours is unlimited. A 10% overload capacity is available for one hour in twelve. Ratings are in accordance with ISO-8528/1, overload power in accordance with ISO-3046/1, BS5514, AS2789, and DIN 6271. For limited running time and base load ratings consult the factory. The generator set manufacturer reserves the right to change the design or specifications without notice and without any obligation or liability whatsoever.

GENERAL GUIDELINES FOR DERATION: Altitude: Derate 0.5% per 100m (328 ft.) elevation above 1000m (3279 ft.)
Temperature: Derate 1.0% per 10°C (18°F) temperature above 40°C (104°F).

APPLICATION & ENGINEERING DATA

GENERAL ENGINE DATA MITSUBISHI S16R-YIPTA-2

TYPE	4 CYCLE, WATER COOLED
ASPIRATION	TURBOCHARGED, AFTER COOLER
CYLINDER ARRANGEMENT	V16
No. OF CYLINDERS	16
BORE mm(in.)	170 (6.69)
STROKE mm(in.)	180 (7.09)
DISPLACEMENT liter(cubic in.)	65.37 (3989)
COMPRESSION RATIO	14.0:1
STEADY STATE SPEED STABILITY BAND AT ANY CONSTANT LOAD	
ELECTRIC GOVERNOR	±0.25% OR BETTER
MAXIMUM OVERSPEED CAPACITY	2100 RPM
MOMENT OF INERTIA OF ROTATING COMPONENTS INCLUDES STD. FLYWHEEL— kgf·m (lbf·ft)	80.83 (1918)
CYCLIC SPEED VARIATION WITH FLYWHEEL AT 1800 rpm	1/283
	1500 rpm 1/188

AIR INLET SYSTEM

MAXIMUM INTAKE AIR RESTRICTION(INCLUDES PIPING) WITH CLEAN FILTER ELEMENT—mm H ₂ O (in.H ₂ O)	400 (15.7)
WITH DIRTY FILTER ELEMENT—mm H ₂ O (in.H ₂ O)	635 (25.0)

EXHAUST SYSTEM

MAX. ALLOWABLE BACK PRESSURE—mm H ₂ O (in.H ₂ O)	600 (23.6)
--	------------

LUBRICATION SYSTEM

OIL PRESSURE AT IDLE—kgf/cm ² (psi)	2~3 (29~43)
OIL PRESSURE AT RATE SPEED—kgf/cm ² (psi)	5~6.5 (71~93)
MAX. OIL TEMPERATURE—°C(°F)	110 (230)
OIL CAP. OF STANDARD PAN HIGH—liter (U.S. gal.)	200 (52.8)
OIL CAP. OF STANDARD PAN LOW—liter (U.S. gal.)	140 (37.0)
TOTAL SYS. CAP. (INCLUDES FILTER)—liter (U.S. gal.)	230 (60.8)
MAX. ANGLE OF INSTALLATION (STD. PAN) FRONT DOWN (ENGINE ONLY)	5°
	FRONT UP 5°
	SIDE TO SIDE 22.5°

FUEL SYSTEM

FUEL INJECTOR	MITSUBISHI PS8 X 2
MAX. SUCTION HEAD OF FEED PUMP—mm Hg (in. Hg)	110 (4.3)
MAX. STATIC HEAD OF LEAK PIPE—mm Hg (in. Hg)	370 (14.6)

STARTING SYSTEM

BATTERY CHARGING ALTERNATOR— V-Ah	24-30
STARTING MOTOR CAPACITY— V-kW	24-7.5 X 2
MAX. ALLOWABLE RESISTANCE OF CRANKING CIRCUIT— m Ω	1.5
RECOMMENDED MINIMUM BATTERY CAPACITY AT 5 °C(41 °F) AND ABOVE—Ah	300
BELOW 5 °C(41 °F) THROUGH— 5 °C(23 °F)	600

ENGINE MOUNTING

MAXIMUM BENDING MOMENT AT REAR FACE OF FLYWHEEL HOUSING kgf·m (lbf·ft)	450 (3256)
--	------------

COOLING SYSTEM

COOLANT CAPACITY	111 gal.
MAX. EXTERNAL FRICTION HEAD AT ENGINE OUTLET	5 psi
MAX. STATIC HEAD OF COOLANT ABOVE CRANKSHAFT CENTER	32.8 ft.
MAX. OUTLET PRESSURE OF ENGINE WATER PUMP	28.6 psi
STANDARD THERMOSTAT (MODULATING) RANGE	160~185 °F
MAX. COOLANT TEMP. AT ENGINE OUTLET	208 °F
MIN. COOLANT EXPANSION SPACE—% OF SYS. CAPACITY	10
MAX. AIR REST. ON DISCHARGE SIDE OF RAD. AND FAN	.4 in. H ₂ O

ITEM	STANDBY		PRIME	
	60Hz	50Hz	60Hz	50Hz
	1800	1500	1800	1500
BRAKE HORSE POWER WITHOUT FAN	2346 HP	2172 HP	2131 HP	1984 HP
BRAKE MEAN EFFECTIVE PRESSURE WITHOUT FAN	259 psi	287 psi	235 psi	263 psi
MEAN PISTON SPEED	2126 ft/min	1772 ft/min	2126 ft/min	1772 ft/min
MAX. REGENERATIVE POWER ABSORPTION CAP. NO FAN	258 HP	188 HP	258 HP	188 HP
INTAKE AIR FLOW	4979 CFM	4520 CFM	4484 CFM	4131 CFM
EXHAUST GAS FLOW	13171 CFM	11970 CFM	11899 CFM	10911 CFM
COOLANT FLOW	489 GPM	436 GPM	489 GPM	436 GPM
COOLING AIR FLOW (STD. FAN)	68855 CFM	68855 CFM	68855 CFM	68855 CFM
FAN LOSS HORSE POWER (STD. FAN)	67 HP	40 HP	67 HP	40 HP
RADIATED HEAT TO AMBIENT	7027 BTU/min.	6374 BTU/min.	6340 BTU/min.	5822 BTU/min.
HEAT REJECTION TO COOLANT	58558 BTU/min.	53116 BTU/min.	52832 BTU/min.	48518 BTU/min.
HEAT REJECTION TO EXHAUST	69121 BTU/min.	60829 BTU/min.	61751 BTU/min.	55564 BTU/min.

FUEL CONSUMPTION

	60Hz	50Hz
DIESEL, GPH AT % OF LOAD		
100%	96	95
75%	74	72
50%	54	49

CONTROL PANEL

The DGC-2020 Digital Genset Controller provides integrated engine-genset control, protection, and metering in a single package. Microprocessor based technology allows for exact measurement, setpoint adjustment, and timing functions. Front panel controls and indicators enable quick and simple DGC-2020 operation. A wide temperature-range liquid crystal display (LCD) with backlighting can be viewed under a wide range of ambient light and temperature conditions.

Features

- Generator Metering
- Engine Metering
- Genset Control
- Engine Protection
- Generator Protection (27, 59, 810, 81U)
- SAE J1939 Engine ECU communications
- Multilingual capability
- Remote RS-485 communications for Optional RDP-110 Remote Annunciator
- Extremely rugged, fully encapsulated design
- 16 programmable contact inputs
- 7 contact outputs: (3) 30 Adc contacts (4) programmable 2 Adc rated contacts
- Wide Ambient Temperature Range
- Modbus Communications with RS-485
- Battery Backup for Real Time Clock
- LCD Heater allows for use of DGC-2020 in temp. down to -40°C
- UL recognized, CSA certified, CE approved
- HALT (Highly Accelerated Life Tests) tested
- IP 54 Front Panel rating with integrated gasket
- NFPA 110 Level Compatible

Options

- Additional (8) Programmable 2 Adc contacts
- Remote Dial-out and Dial-in capability with Internal Modem
- Enhanced Generator Protection 51 and 47

GENERATOR SPECIFICATIONS

STANDARDS

HC7 industrial generators meet the requirements of BS5000, VDE0530, UTE5100, NEMA MG1-22, CEMA, IEC34, CSA22.2 AND AS1359.

EXCITATION SYSTEMS

MX321 AVR

This most sophisticated AVR is incorporated into the permanent magnet generator.

The PMG provides power via the AVR to the main exciter, giving a source of constant excitation power independent of generator output. The main exciter output is then fed to the main rotor, through a full wave bridge, protected by a surge suppressor. The AVR has built-in protection against sustained over-excitation, caused by internal or external faults. This de-excites the machine after a minimum of 5 seconds.

The three phase rms voltage sensing provides voltage regulation of $\pm 0.5\%$. It is particularly suitable for applications with greatly unbalanced or highly non-linear loads.

Over voltage protection is built-in and short circuit current level adjustment is an optional facility.

An engine relief load acceptance feature can enable full load to be applied to the generator set in a single step.

VOLTAGE REGULATION

Voltage regulations specified above are from no load to full load including cold to hot variations for any power factor between 0.8 lagging and unity allowing for a 4% engine speed variation. Voltage is adjusted using a trimmer on the AVR.

INSULATION / IMPREGNATION

The insulation system is Class 'H'.

All wound components are impregnated with materials and processes designed specifically to provide protection against the harsh environments encountered in generator applications. Varnishes and resins are selected and developed to provide the high build required for static windings and the high mechanical strength required for rotating components.

WINDINGS & ELECTRICAL PERFORMANCE

All generator stators are wound to 2/3 pitch. This eliminates triplen (3rd, 9th, 15th...) harmonics on the voltage waveform and is found to be the optimum design for trouble-free supply of non linear loads. The 2/3 pitch design avoids excessive neutral currents, sometimes seen with higher winding pitches, when in parallel with the mains.

A fully connected damper winding reduces oscillations during paralleling. This winding, with 2/3 pitch and carefully selected pole and tooth designs, ensures very low waveform distortion.

TELEPHONE INTERFERENCE

THF (as defined by BS4999 Part 40) is better than 2%. TIF (as defined by ASA C50.12) is better than 50.

RADIO INTERFERENCE

The absence of brushgear and the high quality AVR ensure low levels of interference with radio transmissions.

Additional RFI suppression may be supplied if required.

ENCLOSURE

IP22 (NEMA 1) is standard for all industrial generators. Protection to IP23 (60 degrees from vertical) is available as an option at reduced ratings (5% derate).

Inlet air filters are available as an option on all generators, at reduced ratings (5% derate).

SHAFT

All generator rotors are dynamically balanced to better than BS6861: Part 1 Grade 2.5 for minimum vibration in operation.

QUALITY ASSURANCE

Generators are manufactured using production procedures having a quality assurance level to BS EN ISO 9001.

STANDARD FEATURES AND ACCESSORIES

Standard Features

- Heavy duty steel base
- Vibration isolators
- Oil drain valve with extension
- Flex exhaust connector
- Battery rack
- Battery cables
- Water jacket heater
- Owners manual
- Electronic Isochronous Governor
- PMG exciter

Accessories

- Generator strip heater
- Line circuit breaker
- DGC-2020 Enhanced generator protection
- DGC-2020 Internal Modem
- DGC-2020 Programmable Aux. Contacts qty. (8) 2Adc
- Surface Mount Remote Annunciator
- Flush Mount Remote Annunciator
- Analog Auto-Start Control Panel

Accessories

- Exhaust silencer
- Silencer mounting kit for enclosure
- Weather enclosure
- Sound attenuated enclosure
- Sub-base fuel tank
- Flexible fuel lines
- Day tank
- Oil pan heater
- Battery
- Battery heater
- Battery charger

WEIGHTS AND DIMENSIONS

DS1600M

Overall Size, L x W x H, in.: (220" x 100" x 103")

Weight (wet): 26,000 lbs.

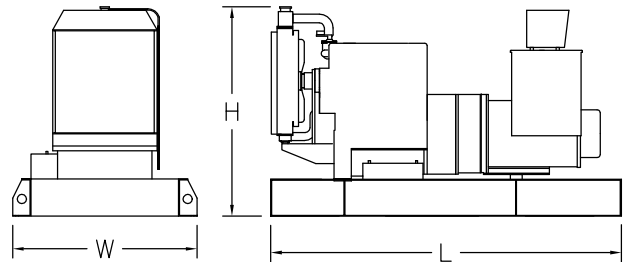

Note: This drawing is provided for reference only and should not be used for planning installation. Contact your local distributor for more detailed information.

TAYLOR POWER SYSTEMS

461 Hwy. 49S
Richland, Mississippi 39218
Phone (601)-932-5674
Toll Free 1-800-367-7639
FAX (601)-932-4028
Web Site www.taylorpower.com

DISTRIBUTED BY: