

# TAYLOR®

## POWER SYSTEMS

### BATTERY SPECIFICATION SHEET

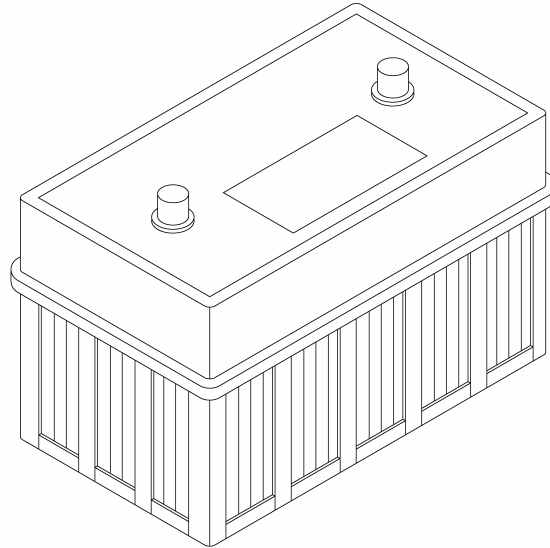

- Taylor Power Systems selects batteries to meet the engine manufacturer's specifications and to comply with NFPA 110 requirements for engine cranking cycles.
- Manufactured with Silver Calcium Alloy to ensure a longer shelf life and take less time to recharge, compared with ordinary calcium batteries.
- Maintenance free and can withstand long periods of downtime.

UNIT MODEL	BATTERY MODEL	COLD CRANKING AMPS @ 0° F	RESERVE CAPACITY MINUTES
DS9M2 – DS20M2 GS25	GROUP 26	525	80
GS45 – GS125	PC31650A	650	180
DS30M2 – DS150M2	PC31925A	925	180
DS200M2	QTY. (2) GROUP 4D	900 EACH	285 EACH
DS250M2 – DS600	QTY. (2) GROUP 8D	1300 EACH	450 EACH
DS800 – DS2000	QTY. (4) GROUP 8D	1300 EACH	450 EACH

---

**TAYLOR POWER SYSTEMS**  
 461 HIGHWAY 49 SOUTH  
 RICHLAND, MS. 39218  
 PHONE: 601-932-5674  
 TOLL FREE: 1-800-367-7639